

Columns and Pilasters

- Concentric axial
- Interaction
- Bearing walls



Guastavino Vaulting

Boston Public Library



Guastavino Vaulting

Boston Public Library



University of Michigan, TCAUP

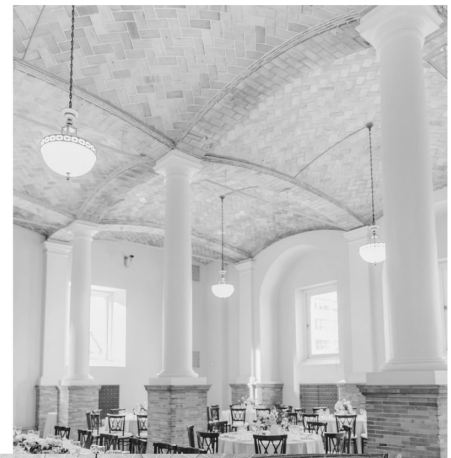

Masonry

Slide 3 of 36

Guastavino Vaulting

John Ochsendorf

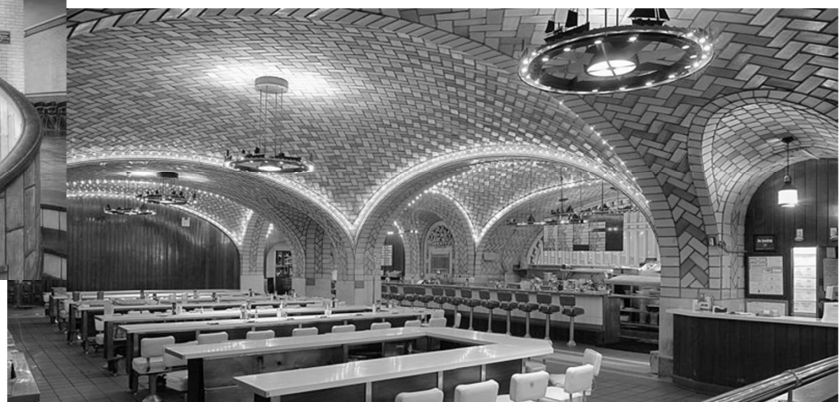
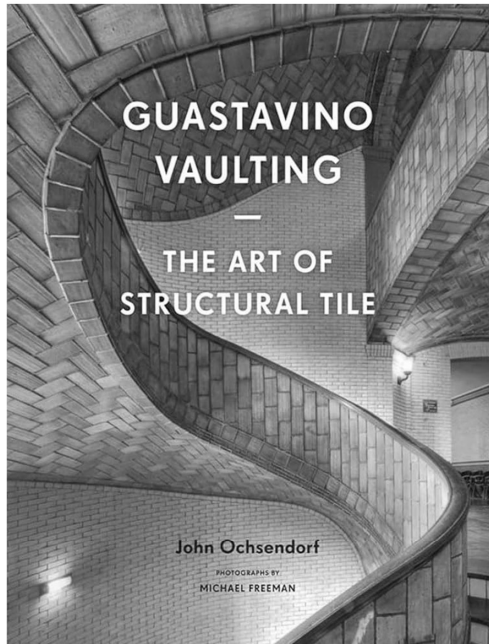

University of Michigan, TCAUP

Masonry

Slide 4 of 36

Types of Vertical Supports

Columns

- width/thickness ≤ 3
- separate member

Piers

- like a column but within wall

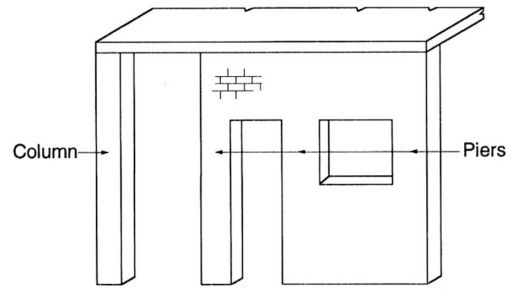

(a) Piers and Column

Pilasters

- integral with wall
- resists out of plane bending
- either or both sides project from wall
- stiffer than wall so carry more moment
- expansion joints prevent cracking

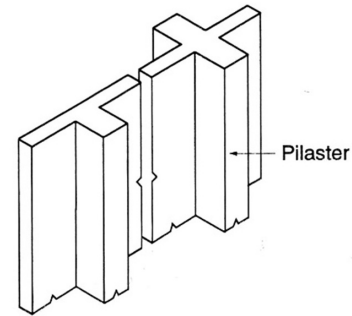

(b) Pilasters as Parts of a Wall

Buttresses

- tapered top to bottom
- enlarged at base to resist overturning
- if thrust line is within kern, all compression

Columns

carry vertical load but also moment

- eccentric loading
 - can be unreinforced (short)
- reinforcement required by TMS 402
- $\rho_{min} = 0.0025$
 - $\rho_{max} = 0.04$
 - $\rho = A_s/bd$
 - ties – TMS 402 5.3.1.4.
 - better in contact w/ bars
 - running bond

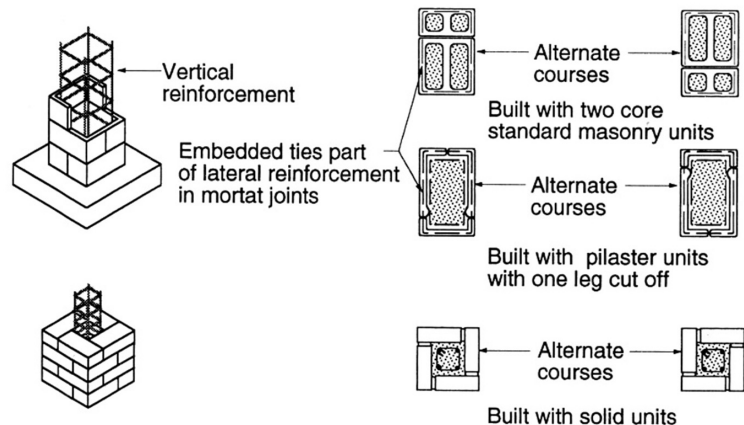

(a) Columns

Concentric Axial Compression

A_{st} = area of **laterally tied steel**

TMS 402 CODE

5.3.1.4 Lateral ties — Lateral ties shall conform to the following:

- Vertical reinforcement shall be enclosed by lateral ties at least $\frac{1}{4}$ in. (6.4 mm) in diameter.
- Vertical spacing of lateral ties shall not exceed 16 longitudinal bar diameters, 48 lateral tie bar or wire diameters, or least cross-sectional dimension of the member.
- Lateral ties shall be arranged so that every corner and alternate longitudinal bar shall have lateral support provided by the corner of a lateral tie with an included angle of not more than 135 degrees. No bar shall be farther than 6 in. (152 mm) clear on each side along the lateral tie from such a laterally supported bar. Lateral ties shall be placed in grout. Where longitudinal bars are located around the perimeter of a circle, a complete circular lateral tie is permitted. Lap length for circular ties shall be 48 tie diameters.
- Lateral ties shall be located vertically not more than one-half lateral tie spacing above the top of footing or slab in any story, and shall be spaced not more than one-half a lateral tie spacing below the lowest horizontal reinforcement in beam, girder, slab, or drop panel above.

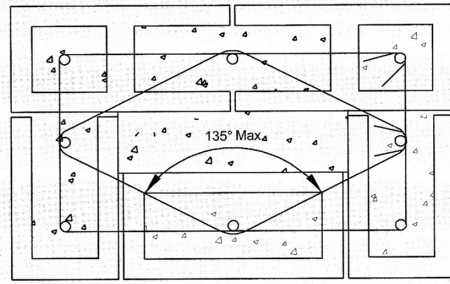

Clear space between bars greater than 6 in.

Figure CC-5.3-2 — Example of a lateral tie included angle for a CMU column

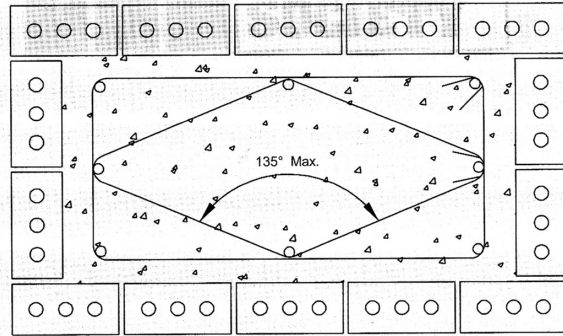

Clear space between bars greater than 6 in.

Figure CC-5.3-3 — Example of a lateral tie included angle for a clay masonry column

Pilasters

carry vertical load but also moment

- integral with wall
- resists out of plane bending
- either or both sides project from wall
- stiffer than wall so carry more moment
- expansion joints prevent cracking
- running bond w/ wall
- anchored to wall at 48 in. o.c. max.

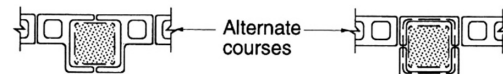
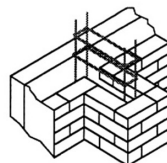
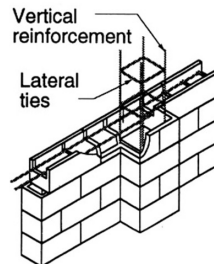

Built with pilaster units

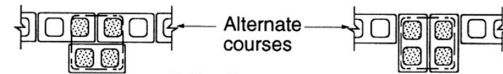

Built with two core standard masonry units

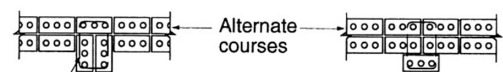

Single face with solid units



Double face with solid units

(b) Pilasters

Column Behavior

modes of failure:

- vertical splitting of masonry shell and grout core – typical for unreinforced columns
- simultaneous splitting (as above) and buckling of vertical reinforcement between ties
- like above + failure of ties (at hooks) with reinforcement buckling over two or more courses

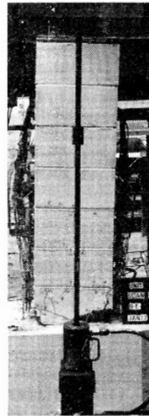

a) Test under cyclic lateral load

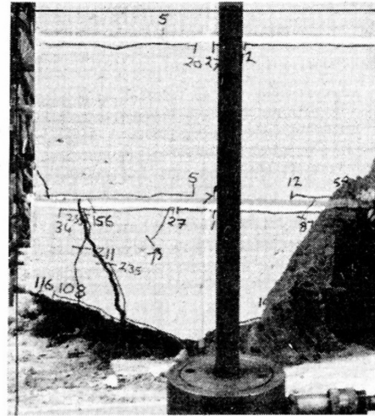

b) Full capacity retained at large lateral displacement

Effect of Slenderness

- effects buckling
- more susceptible to additional moment: P-Δ effect
- TMS 402 uses the ψ factor

9.3.5.4.3 The strength level moment, M_u , shall be determined either by a second-order analysis, or by a first-order analysis and Equations 9-27 through 9-29.

$$M_u = \psi M_{u,0} \quad \text{(Equation 9-27)}$$

Where $M_{u,0}$ is the strength level moment from first-order analysis.

$$\psi = \frac{1}{1 - \frac{P_u}{P_e}} \quad \text{(Equation 9-28)}$$

Where:

$$P_e = \frac{\pi^2 E_m I_{eff}}{h^2} \quad \text{(Equation 9-29)}$$

For $M_u < M_{cr}$, I_{eff} shall be taken as $0.75 I_n$. For $M_u \geq M_{cr}$, I_{eff} shall be taken as I_{cr} . P_u/P_e cannot exceed 1.0.

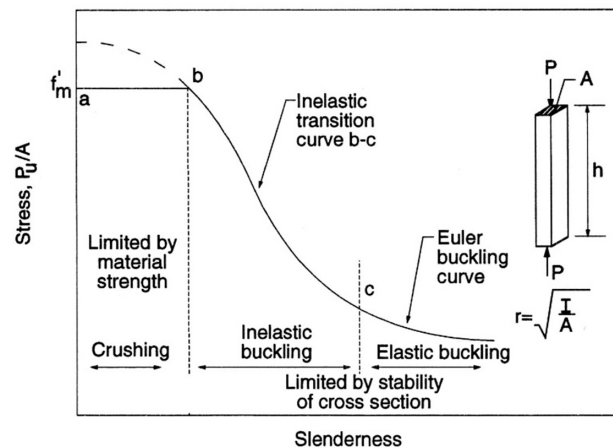

TMS 402 CODE

4.3.3 Radius of gyration

Radius of gyration shall be calculated using the average net cross-sectional area of the member considered.

$$r = \sqrt{I/A}$$

COMMENTARY

4.3.3 Radius of gyration

The radius of gyration is the square root of the ratio of bending moment of inertia to cross-sectional area. Because stiffness is based on the average net cross-sectional area of the member considered, this same area should be used in the calculation of radius of gyration.

Design Considerations

- minimum eccentricity: $0.1 \times$ side dimension of column
- minimum side distance = 8"
- effective height – based on boundary conditions top and bottom
- when in doubt use clear height between floors

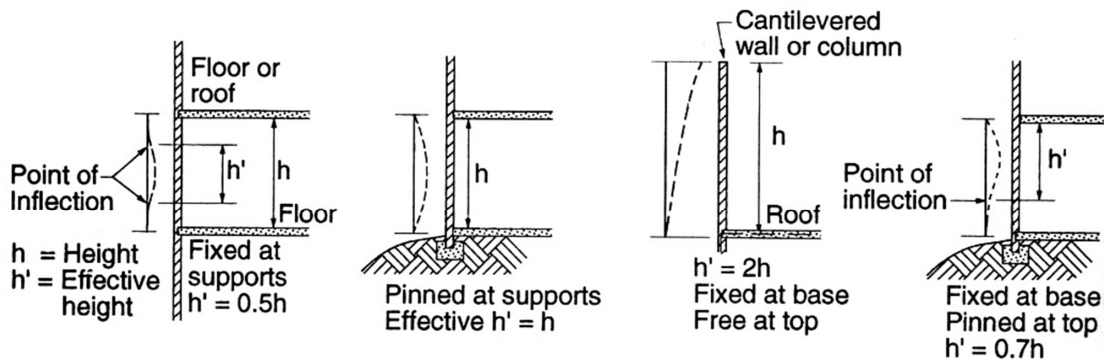
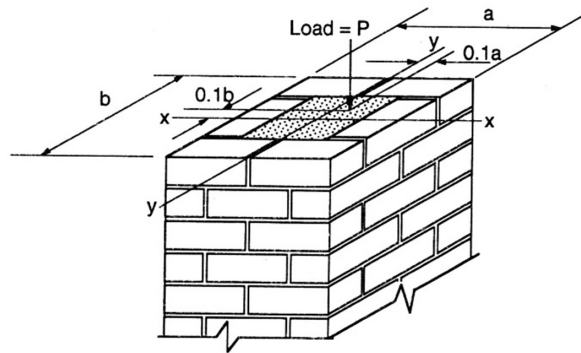

Figure 9.6 Effective height of masonry columns (from Ref. 9.1).

Design for Axial Load and Bending

methods based on degree of eccentricity

if load is within the kern (middle 1/3) then section is in compression. This eccentricity = e_k

$$e_k = \text{Section modulus} / \text{Area}$$

Case 1:

compression controls

$$e < e_k \text{ full section in compression}$$

Case 2: Category I

compression controls

$$e > e_k \text{ initial cracking – steel in compression}$$

Case 2: Category II

compression controls

$$e > e_k \text{ more cracking – steel in tension}$$

Case 2: Category III

tension controls

$$e > e_k \text{ more cracking – steel in tension}$$

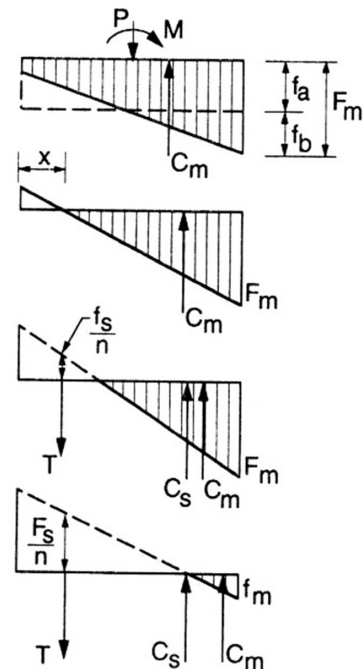
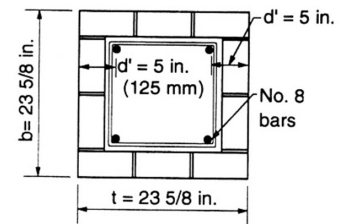

Combined Bending and Axial Load flowchart

zero when A_s at center

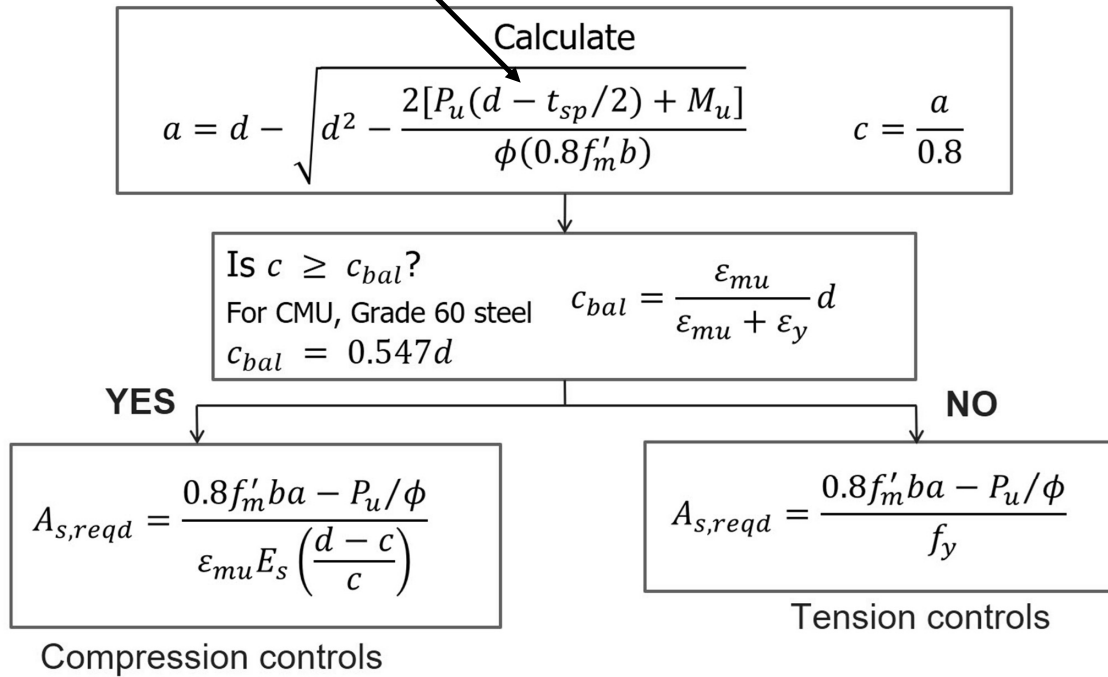

Arches

TEK 14-14

Minor Arch

- 6 ft span limit
- rise to span ratio less than 0.15
about 11" height for 6' span
- can carry 1500 lbs / ft. of span

Major Arch

- deeper
- longer span

