

Masonry Walls

Empirical Design

- Non-reinforced axial compression
- Reinforced axial compression

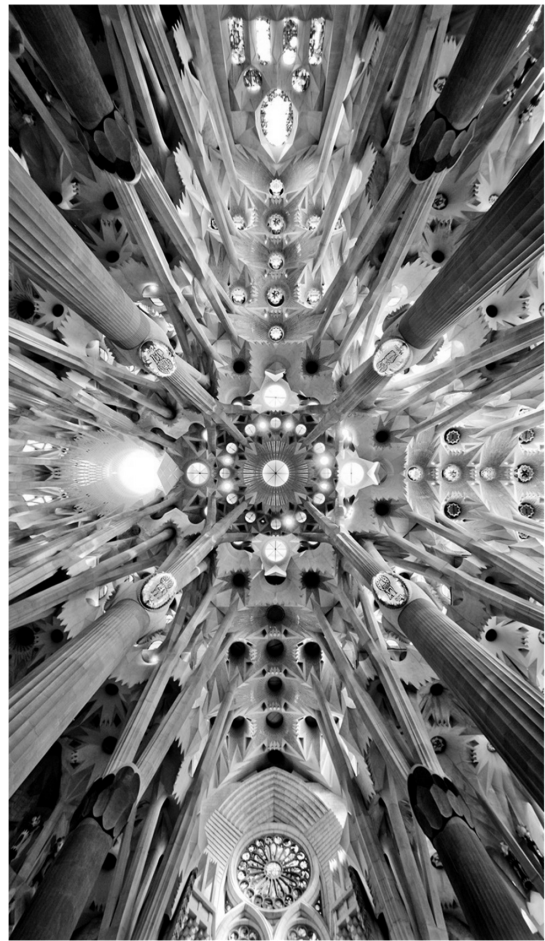

Sagrada Familia
Barcelona, Spain
Arch: Antoni Gaudi

Sagrada Familia 1882 – 2026?

Antoni Gaudi 1852 – 1926
Barcelona, Spain



Sagrada Familia 1882 – 2026?

Antoni Gaudi 1852 – 1926

Barcelona, Spain

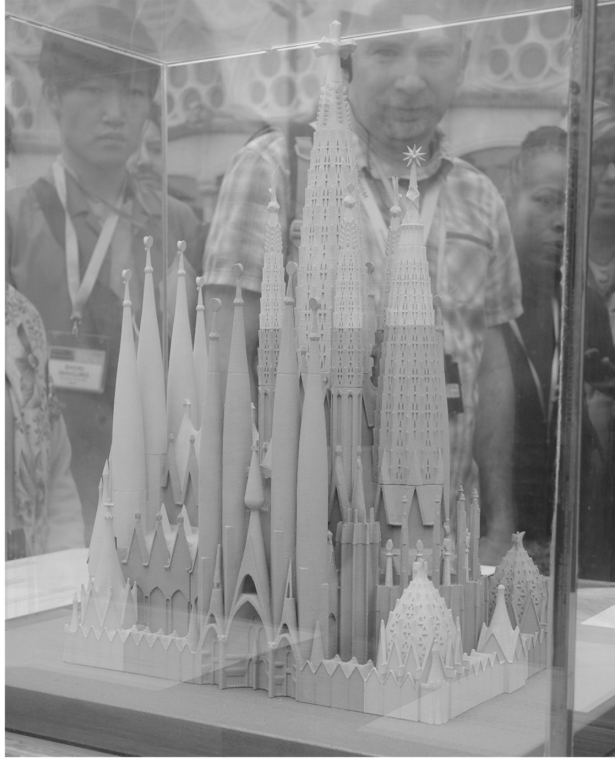

University of Michigan, TCAUP



Masonry

Slide 3 of 39

Sagrada Familia 1882 – 2026?

Antoni Gaudi 1852 – 1926

Barcelona, Spain



University of Michigan, TCAUP



Masonry

Slide 4 of 39

Sagrada Familia 1882 – 2026?

Antoni Gaudi 1852 – 1926

Barcelona, Spain



University of Michigan, TCAUP



Masonry

Slide 5 of 39

Sagrada Familia 1882 – 2026?

Antoni Gaudi 1852 – 1926

Barcelona, Spain

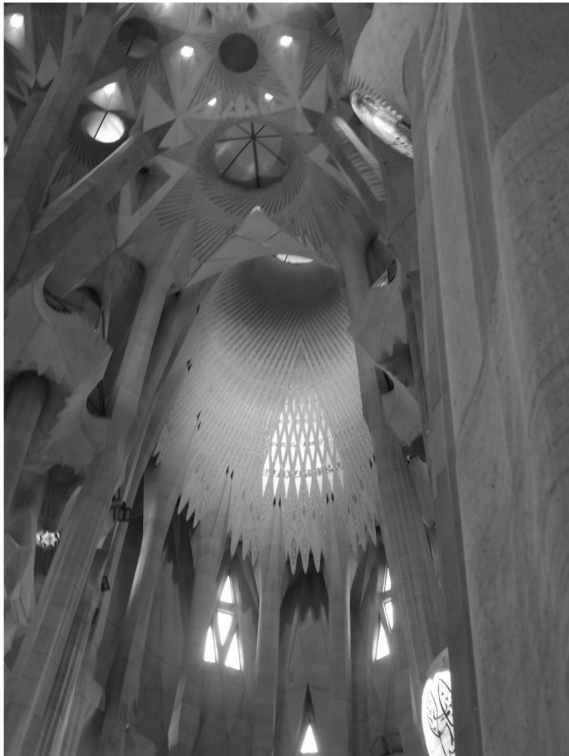

University of Michigan, TCAUP

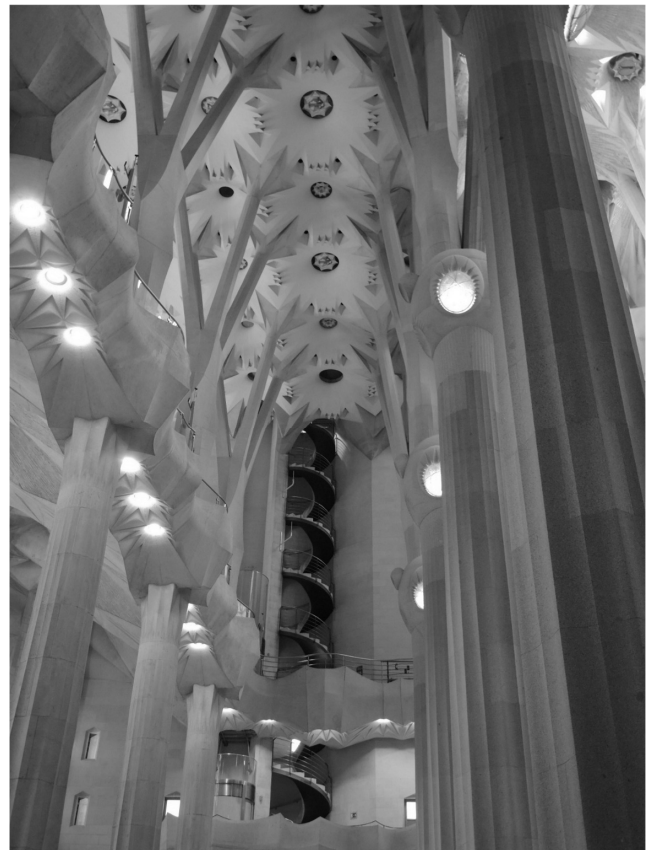

Masonry

Slide 6 of 39

Sagrada Familia 1882 – 2026?

Antoni Gaudi 1852 – 1926

Barcelona, Spain



University of Michigan, TCAUP



Masonry

Slide 7 of 39

Sagrada Familia 1882 – 2026?

Antoni Gaudi 1852 – 1926

Barcelona, Spain



University of Michigan, TCAUP

Masonry

Slide 8 of 39

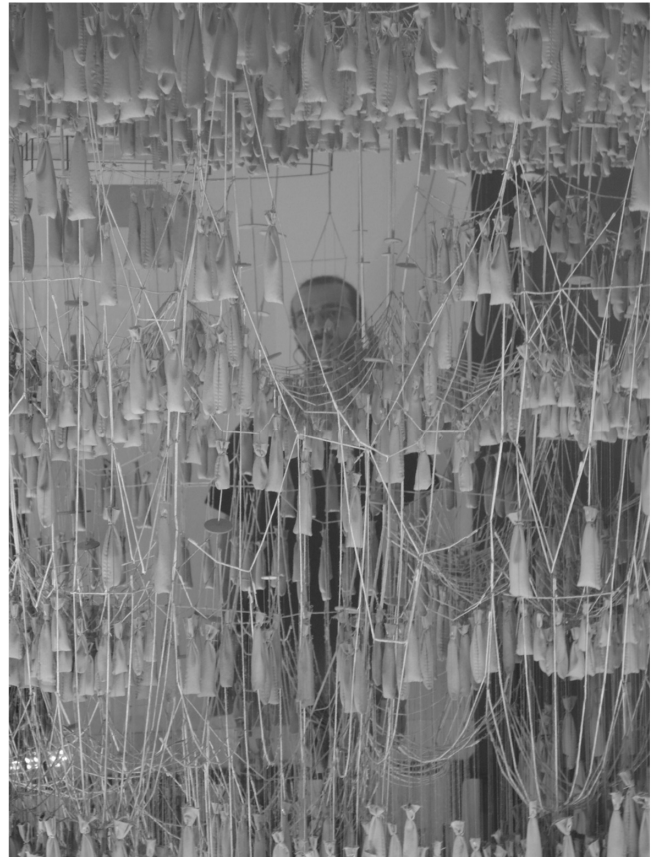

Sagrada Família 1882 – 2032?

Antoni Gaudí 1852 – 1926

Barcelona, Spain



University of Michigan, TCAUP

Masonry

Slide 9 of 39

Casa Milà 1906 – 1912

Antoni Gaudí 1852 – 1926

Barcelona, Spain



University of Michigan, TCAUP

Masonry

Slide 10 of 39

Casa Milà 1906 – 1912

Antoni Gaudi 1852 – 1926

Barcelona, Spain



University of Michigan, TCAUP

Masonry

Slide 11 of 39

Casa Milà 1906 – 1912

Antoni Gaudi 1852 – 1926

Barcelona, Spain



University of Michigan, TCAUP

Masonry

Slide 12 of 39

Casa Milà 1906 – 1912
Antoni Gaudi 1852 – 1926
Barcelona, Spain



University of Michigan, TCAUP

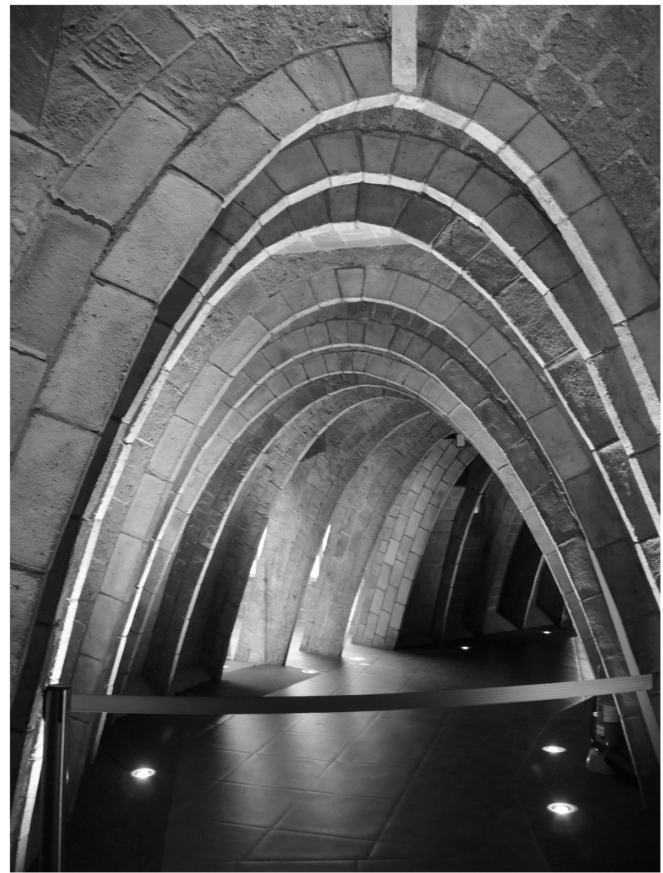

Masonry

Slide 13 of 39

Casa Milà 1906 – 1912
Antoni Gaudi 1852 – 1926
Barcelona, Spain



University of Michigan, TCAUP

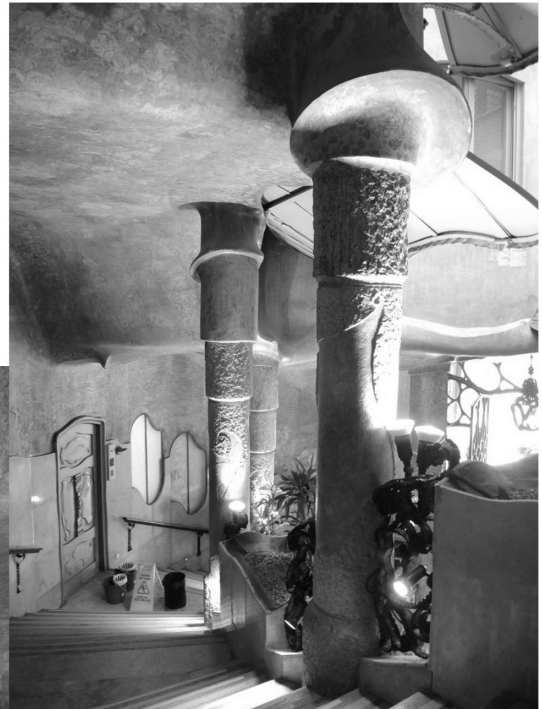

Masonry

Slide 14 of 39

Park Güell 1900 –
Antoni Gaudi 1852 – 1926
Barcelona, Spain



University of Michigan, TCAUP

Masonry



Slide 15 of 39

Park Güell 1900 –
Antoni Gaudi 1852 – 1926
Barcelona, Spain



University of Michigan, TCAUP

Masonry



Slide 16 of 39

Park Güell 1900 –
Antoni Gaudi 1852 – 1926
Barcelona, Spain



University of Michigan, TCAUP



Masonry

Slide 17 of 39

Park Güell 1900 –
Antoni Gaudi 1852 – 1926
Barcelona, Spain



University of Michigan, TCAUP

Masonry

Slide 18 of 39

Masonry Strength

f'_m – specified masonry strength
 f'_{mt} - tested masonry strength,
 based on prism test

- unit strength – f_u
- mortar type – M, S, N, O
- grout strength – f'_g
- quality (inspected, full joints)

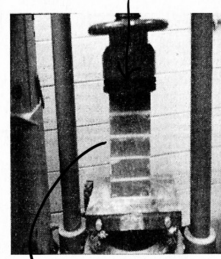

Prisms with Full Size Units

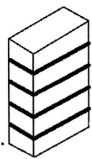

Solid unit prism

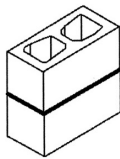

Hollow unit prism

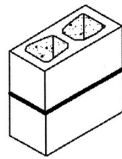

Grouted hollow prism

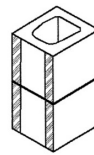

Hollow unit

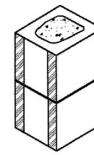

Grouted hollow unit

Prisms reduced by saw cutting

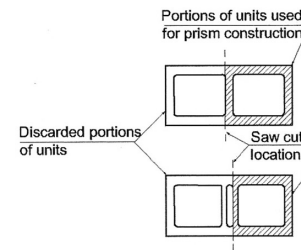

Prisms with Saw-Cut Half Units

Masonry Strength

Masonry strength, f'_m , based on unit strength, f_u , and mortar type



Clay Masonry

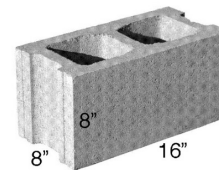

Concrete Masonry

TMS 602 1.4 table 1.

Required Net Area Compressive Strength of Clay Masonry Units (psi) f_u		f'_m For Net Area Compressive Strength of Masonry (psi)
When Used With Type M or S Mortar	When Used With Type N Mortar	
1,700	2,100	1,000
3,350	4,150	1,500
4,950	6,200	2,000
6,600	8,250	2,500
8,250	10,300	3,000
9,900	--	3,500
11,500	--	4,000

(From Masonry Standards Joint Committee Specifications for Masonry Structures, ACI 530.1/ASCE 6/TMS 602-99)

Required Net Area Compressive Strength of Concrete Masonry Units (psi) f_u		f'_m For Net Area Compressive Strength of Masonry (psi)
When Used With Type M or S Mortar	When Used With Type N Mortar	
1,250	1,300	1,000
1,900	2,150	1,500
2,800	3,050	2,000
3,750	4,050	2,500
4,800	5,250	3,000

(From International Building Code 2000 and Masonry Standards Joint Committee Specifications for Masonry Structures, ACI 530.1/ASCE 6/TMS 602-99)

Constructive Properties

Typical Values

Property		Clay Masonry	Concrete Masonry
Unit strength		8000 <i>psi</i>	2000 <i>psi</i>
Type N mortar	f'_m	2440 <i>psi</i>	1750 <i>psi</i>
	E_m	1.70×10^6 <i>psi</i>	1.58×10^6 <i>psi</i>
Type M or S mortar	f'_m	2920 <i>psi</i>	2000 <i>psi</i>
	E_m	2.05×10^6 <i>psi</i>	1.80×10^6 <i>psi</i>

Property	Clay Masonry	Concrete Masonry
Modulus of Elasticity, E_m	$700f'_m$	$900f'_m$
Shear Modulus, G	$0.4E_m$	$0.4E_m$
Coefficient of Creep	$\frac{0.7 \times 10^{-7}}{\text{psi}}$	$\frac{2.5 \times 10^{-7}}{\text{psi}}$

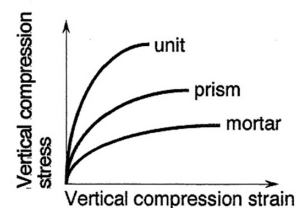

(a) Stress-Strain Relationships

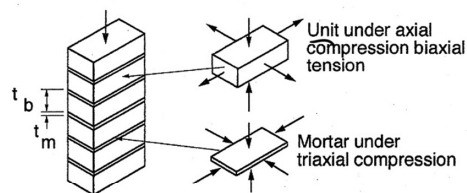

(b) States of Stress of Units and Mortar

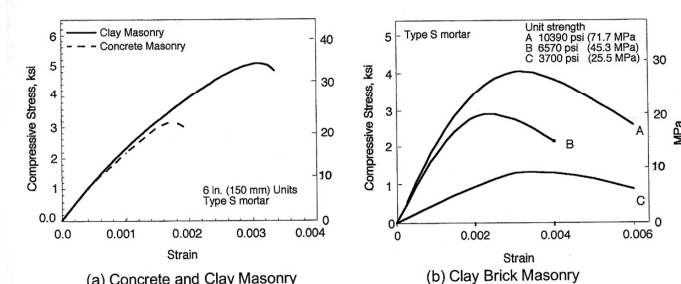

Analysis and Design

Empirical approach

- based on experience ✓
- limits on lateral loading w, E
- limits on height h
- limits on eccentricity (basically no flexure)
- non-reinforced

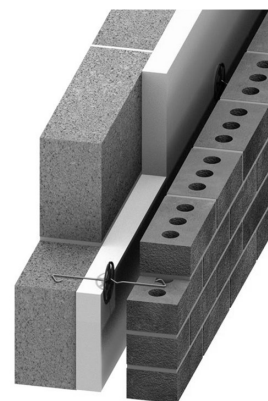

Rational approach

- based on Strength Design (LRFD)
- either reinforced or non-reinforced
- limited by strength



Empirical Design of Concrete Masonry Walls

Application

- non-reinforced ✓
- low lateral loads – wind or seismic ✓
- e.g. exterior curtain walls & interior partitions

Prescriptive Criteria

- wall height to thickness ✓
- shear wall length & spacing ✓
- minimum wall thickness ✓
- maximum building height ✓
- usually with running bond

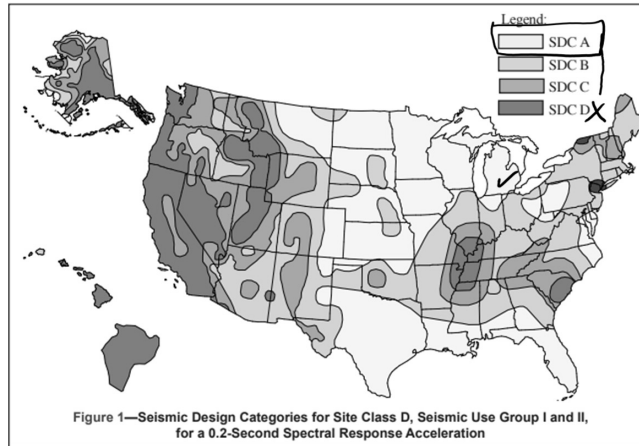
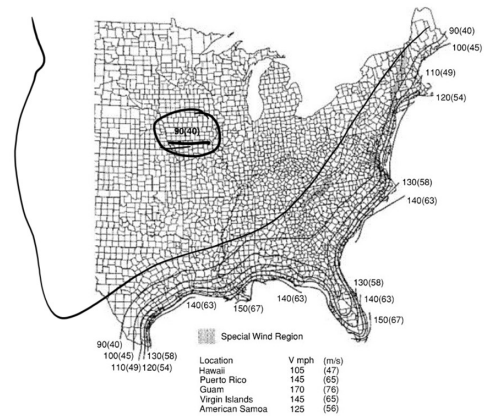

Empirical Design of Concrete Masonry Walls

Three things to check by International Building Code (IBC 2006)

- Seismic Design Category
 - if not part of seismic resisting system – A, B or C
 - if part of the seismic lateral force resisting system – **A only**
- Basic wind speed vs building height (IBC table 1)
- gravity load resultant within the kern (middle 1/3)

Masonry wall type:	Building height, <i>h</i> , ft (m)	Basic wind speed, <i>w</i> , mph (m/s)			
		<i>w</i> ≤ 90 (<i>w</i> ≤ 40)	90 < <i>w</i> ≤ 100 (40 < <i>w</i> ≤ 45)	100 < <i>w</i> ≤ 110 (45 < <i>w</i> ≤ 49)	110 < <i>w</i> (49 < <i>w</i>)
Part of the lateral force-resisting system	<i>h</i> ≤ 35 (11)		Allowed		Not allowed
Interior, not part of the lateral force-resisting system, in buildings other than enclosed ^A	<i>h</i> > 180 (55)		Not allowed		
	60 (18) < <i>h</i> ≤ 180 (55)	Allowed		Not allowed	
	35 (11) < <i>h</i> ≤ 60 (18)		Allowed		Not allowed
Exterior, not part of the lateral force-resisting system	<i>h</i> > 180 (55)		Not allowed		
	60 (18) < <i>h</i> ≤ 180 (55)	Allowed		Not allowed	
	35 (11) < <i>h</i> ≤ 60 (18)		Allowed		Not allowed
Exterior	<i>h</i> ≤ 35 (11)		Allowed		Not allowed

^A Per Minimum Design Loads for Buildings and Other Structures, ASCE 7 (ref. 4).

Minimum wall thickness

- for one story $t \geq 6''$ thick (also for shear walls)
- for more than one story $t \geq 8''$ thick
- t min for unreinforced foundation wall is 8"

Empirical Design of Concrete Masonry Walls

Lateral Support

- horizontal direction
 - cross walls
 - pilasters
 - buttresses
 - structural frame members
- vertical direction
 - floor diaphragms
 - roof diaphragms
 - structural frame members
- maximum interval of support
 - see tables 2 & 3

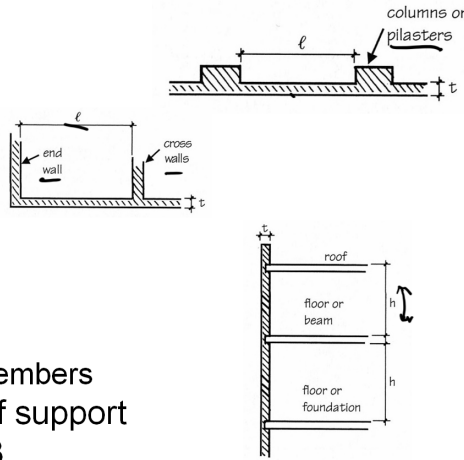

Construction (unreinforced)	Maximum wall length-to-thickness or height-to-thickness ratio ^A
Bearing walls	
Solid units or solid grouted	20
All others	18
Nonbearing walls	
Exterior	18
Interior	36
Cantilever walls^B	
Solid	6
Hollow	4
Parapets (8-in. (203-mm) thick min.) ^B	3

^A Ratios are determined using nominal dimensions. For multiwythe walls where wythes are bonded by masonry headers, the thickness is the nominal wall thickness. When multiwythe walls are bonded by metal wall ties, the thickness is taken as the sum of the wythe thicknesses. Note that Reference 6 includes modified requirements for walls with openings.

^B The ratios are maximum height-to-thickness ratios and do not limit wall length.

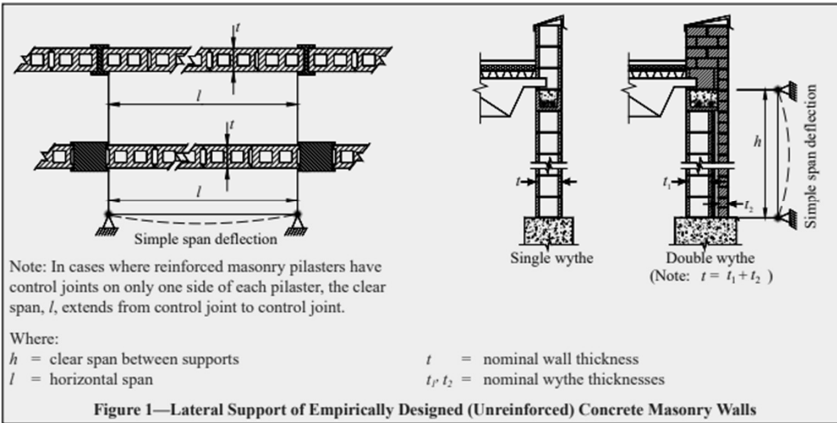

Wall thickness, in. (mm)	6 (152)	8 (203)	10 (254)	12 (305)
Bearing walls				
Solid or solid grouted	10 (3.0) ^B	13.3 (4.1)	16.6 (5.1)	20 (6.1)
All other	9 (2.7) ^B	12 (3.7)	15 (4.5)	18 (5.5)
Nonbearing walls				
Exterior	9 (2.7)	12 (3.7)	15 (4.5)	18 (5.5)
Interior	18 (5.5)	24 (7.3)	30 (9.1)	36 (11)
Cantilever Walls^C				
Solid	3 (0.9)	4 (1.2)	5 (1.5)	6 (1.8)
Hollow	2 (0.6)	2.6 (0.8)	3.3 (1.0)	4 (1.2)
Parapets ^C	1.5 (0.5)	2 (0.6)	2.5 (0.8)	3 (0.9)

^A Note that Ref. 6 includes modified requirements for walls with openings.

^B Unreinforced 6-in. (152-mm) thick bearing walls are limited to one story in height.

^C For these cases, spans are maximum wall heights.

Empirical Design of Concrete Masonry Walls

Allowable Compressive Stress

- solid or fully grouted
 - based on full gross area
- hollow units
 - use correct area - voids
 - most new CMU will be ASTM C90 2006 or later
 - older units use "previous editions"

Gross area compressive strength of unit, psi (MPa)	Allowable compressive stresses based on gross cross-sectional area, psi (MPa) ^A	
	Type M or S mortar	Type N mortar
Solid and Solidly Grouted Masonry (refs. 1, 6):		
Solid concrete brick:		
8,000 (55) or greater	350 (2.41)	300 (2.07)
4,500 (31)	225 (1.55)	200 (1.38)
2,500 (17)	160 (1.10)	140 (0.97)
1,500 (10)	115 (0.79)	100 (0.69)
Grouted concrete masonry:		
4,500 (31) or greater	225 (1.55)	200 (1.38)
2,500 (17)	160 (1.10)	140 (0.97)
1,500 (10)	115 (0.79)	100 (0.69)
Solid concrete masonry units:		
3,000 (21) or greater	225 (1.55)	200 (1.38)
2,000 (14)	160 (1.10)	140 (0.97)
1,200 (8.3)	115 (0.79)	100 (0.69)
Hollow walls (noncomposite masonry bonded ^D):		
Solid units:		
2,500 (17) or greater	160 (1.10)	140 (0.97)
1,500 (10)	115 (0.79)	100 (0.69)

Hollow Unit Masonry (Units Complying With ASTM C 90-06 or Later) (ref. 6)^E:

Hollow loadbearing CMU, $t \leq 8$ in. (203 mm) ^F :		
2,000 (14) or greater	140 (0.97)	120 (0.83)
1,500 (10)	115 (0.79)	100 (0.69)
1,000 (6.9)	75 (0.52)	70 (0.48)
700 (4.8)	60 (0.41)	55 (0.38)
Hollow loadbearing CMU, 8 in. < $t < 12$ in. (203 to 305 mm) ^F :		
2,000 (14) or greater	125 (0.86)	110 (0.76)
1,500 (10)	105 (0.72)	90 (0.62)
1,000 (6.9)	65 (0.49)	60 (0.41)
700 (4.8)	55 (0.38)	50 (0.35)
Hollow loadbearing CMU, $t \geq 12$ in. (305 mm) ^F :		
2,000 (14) or greater	115 (0.79)	100 (0.69)
1,500 (10)	95 (0.66)	85 (0.59)
1,000 (6.9)	60 (0.41)	55 (0.38)
700 (4.8)	50 (0.35)	45 (0.31)
Hollow walls (noncomposite masonry bonded ^D):		
$t \leq 8$ in. (203 mm) ^F	75 (0.52)	70 (0.48)
$8 < t < 12$ in. (203 to 305 mm) ^F	70 (0.48)	65 (0.45)
$t \geq 12$ in. (305 mm) ^F	60 (0.41)	55 (0.38)

Hollow Unit Masonry (Units Complying With Previous Editions of ASTM C 90) (ref. 1)^E:

Hollow concrete masonry units:		
2,000 (14) or greater	140 (0.97)	120 (0.83)
1,500 (10)	115 (0.79)	100 (0.69)
1,000 (6.9)	75 (0.52)	70 (0.48)
700 (4.8)	60 (0.41)	55 (0.38)
Hollow walls (noncomposite masonry bonded ^D):		
Hollow units	75 (0.52)	70 (0.48)

^A Linear interpolation for intermediate values of compressive strength is permitted.

^B Where floor and roof loads are carried on one wythe, the gross cross-sectional area is that of the wythe under load; if both wythes are loaded, the gross cross-sectional area is that of the wall minus the area of the cavity between the wythes. Walls bonded with metal ties shall be considered as noncomposite walls unless collar joints are filled with mortar or grout.

^C Minimum unit face shell thicknesses, for units 10 in. (254 mm) and greater in width, were reduced beginning with ASTM C 90-06. Hence, minimum allowable compressive stresses should be reduced accordingly when using these units. See text for further information.

^D t = nominal unit thickness.

Empirical Design of Concrete Masonry Walls

Anchorage requirements for lateral support of bracing walls

- see figure 2

Anchorage to structural frames

- $\frac{1}{2}$ " bolts at max. 4 ft o.c.
- 4" embedment length in masonry

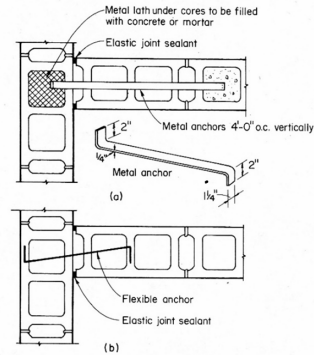
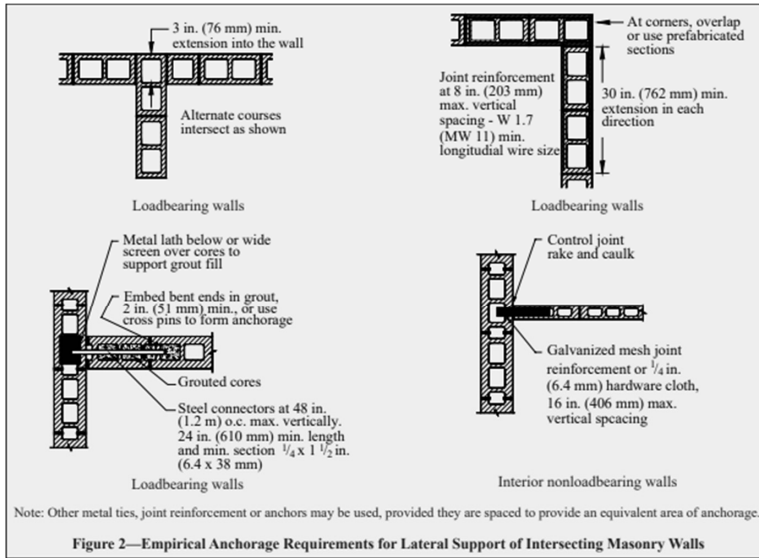

Fig. 4-46. Flexible connections for intersecting walls.

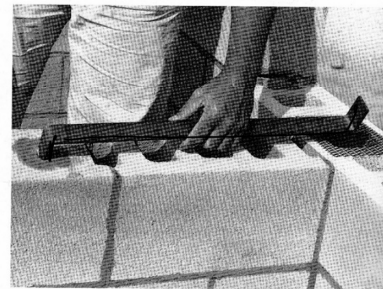
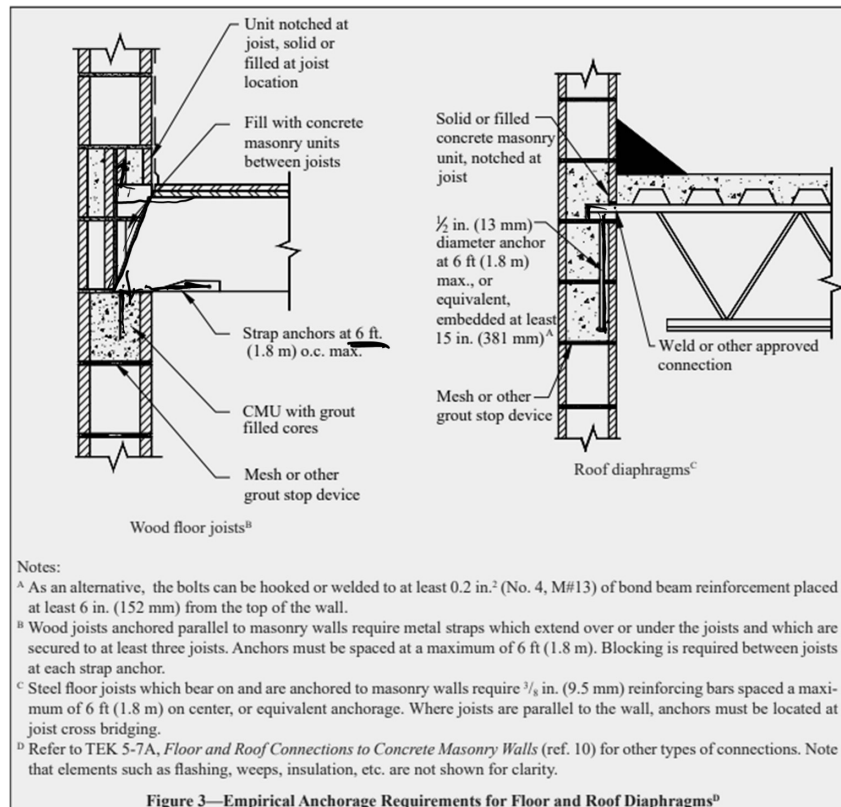

Fig. 4-47. Steel tiebar provides lateral support to wall at right.

Empirical Design of Concrete Masonry Walls

Anchorage requirements for floor and roof diaphragms

- see figure



Empirical Design of Concrete Masonry Walls

Shear walls

- Spacing
 - minimum cumulative length = 40% of building length (Figure 4)
 - shear wall must be longer than $\frac{1}{2}$ its height

Maximum diaphragm ratios

- shear walls spaced so that the length-to-width ratio of each diaphragm transferring lateral forces to the shear wall does not exceed the values in Table 5

Floor or roof diaphragm construction	Maximum length-to-width ratio of diaphragm panel
Cast-in-place concrete	5:1
Precast concrete	4:1
Metal deck with concrete fill	3:1
Metal deck with no fill	2:1
Wood diaphragm	2:1

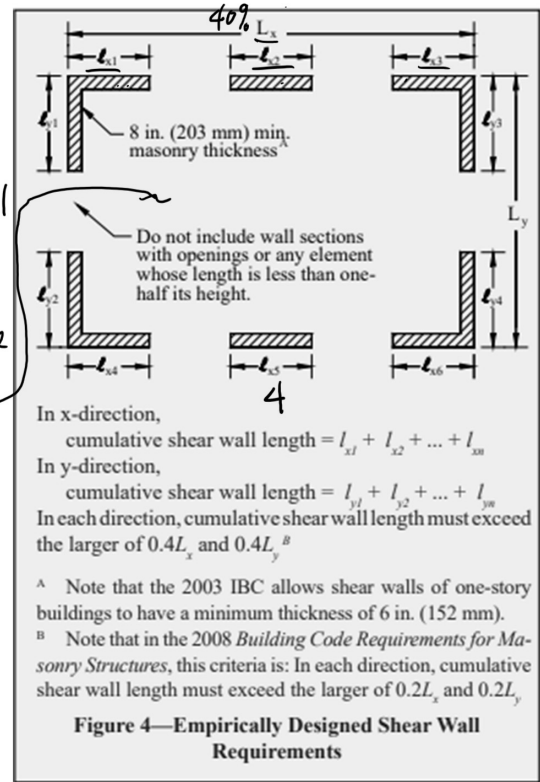

Empirical Design of Concrete Masonry Walls

Lateral Force Resistance

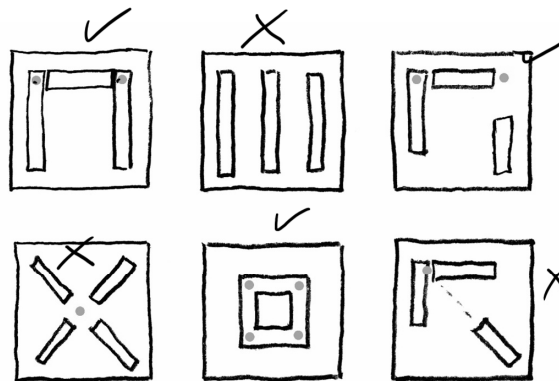

Stability requires at least 2 points of intersection.

Force is more evenly resisted with centroid of walls in the kern of slab

Empirical Design of Concrete Masonry Walls

Bonding of Multiwythe Walls

- masonry headers – solid units
 - 4% of wall surface
 - extend 3" min. into backing wall
 - or overlap from both sides by 3"
 - max. distance between = 24"
- masonry headers – hollow units
 - vertical intervals of min. 34"
 - with 3" overlap
- metal wall ties
 - wire size W2.8
 - one tie for each 4.5 ft² wall surface
 - adjustable ties each 1.77 ft² surface
 - max. vertical spacing = 24" ²
 - max horizontal spacing = 36" ³ < 4.5'
 - hollow walls use rectangular ties
 - min. 2" hook at ends
- prefabricated joint reinforcement
 - 1 crosswire for each 2.67 ft² wall surface
 - max. vertical spacing = 24"
 - min. wire size = W1.7

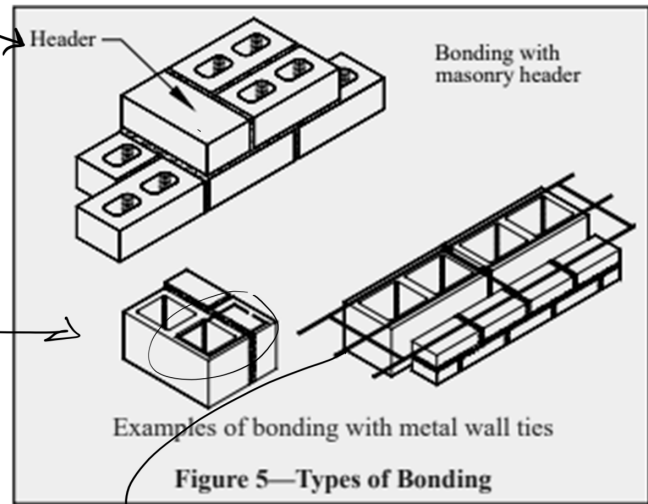

Empirical Design of Concrete Masonry Walls

Other details

- a change in wall thickness requires a grouted course in the thinner section to transfer load to the thicker section
- Chases and recesses in the wall > 12" require a lintel
- Lintel end bearing min. 4" (8" is typical)
- Do not support masonry walls on wood spanning members
- Corbelling – see Figure 6

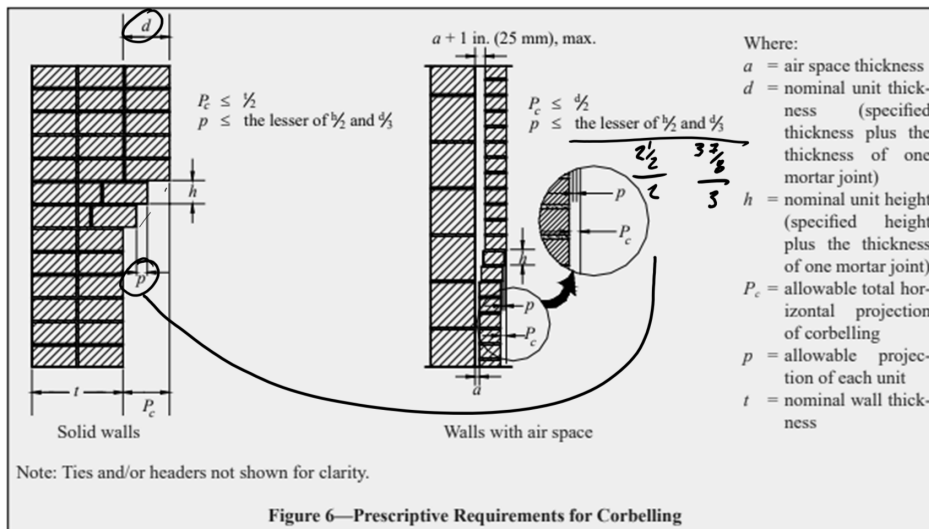

Empirical Design of Concrete Masonry Walls

Interior Partition Walls

- must be isolated from load bearing structure
- gaps must be allowed (not filled with mortar) between partition wall and floor above to accommodate any deflection of the floor.

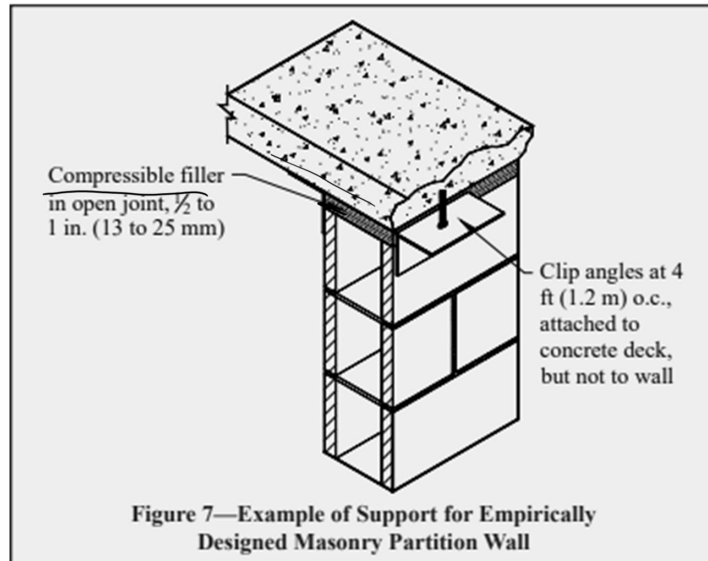

Empirical Concrete Masonry Using TEK 14-8B (2006 IBC)

Given: location, geometry, material
Find: strength (load capacity)

1. Check axial loading – must be within middle 1/3 ✓
2. Check seismic category to be A, B, or C, or only A if part of the seismic lateral force resisting system. ✓
3. Check wind speed (ASCE-7 2005) compare with table 1, TEK 14-8B ✓
4. Check minimum thickness. ✓
1 story = 6" min. 2 story = 8" min.
5. Check lateral support (vertical or horizontal) tables 2 and 3 TEK 14-8B ✓
6. Determine allowable compressive stress f'_m from table 4 TEK 14-8B ✓
7. Allowable load = (stress) (gross area)

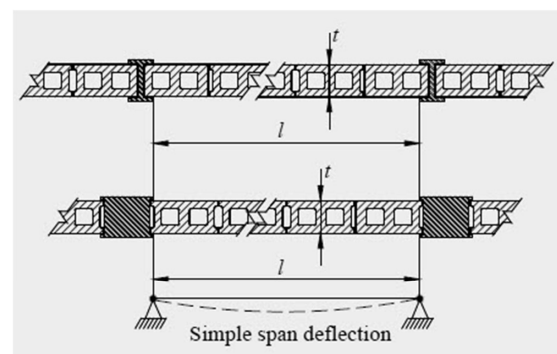
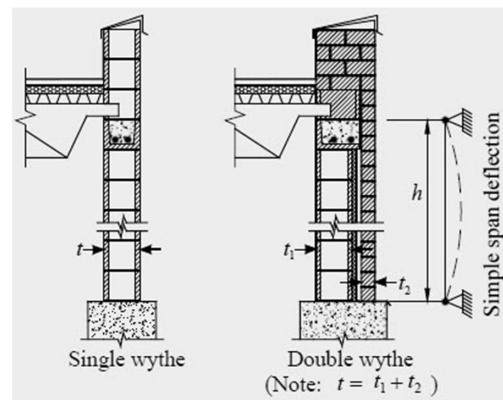

$$P = F \times A_g$$

Empirical Design Example

Given:

8" hollow non-reinforced CMU wall

Ann Arbor, Mich. ✓

Interior ✓

DL = 150 PSF

Find:

LL capacity

Checks:

Axially loaded :

loaded within middle 1/3 (kern) ✓

Seismic Category:

A, B, or C, or only A if part of the seismic lateral force resisting system ✓

Wind:

less than 90mph (by 2006 code) ✓

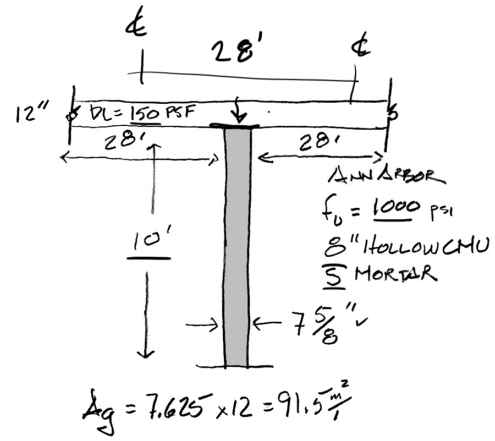

AXIAL LOADING ✓

FOR ANN ARBOR :

SDC → A ✓

WIND LOAD 90 MPH < 110 ✓

Wind and Seismic Limits

Wind for Ann Arbor – 90 mph

SCD for Ann Arbor - Zones A

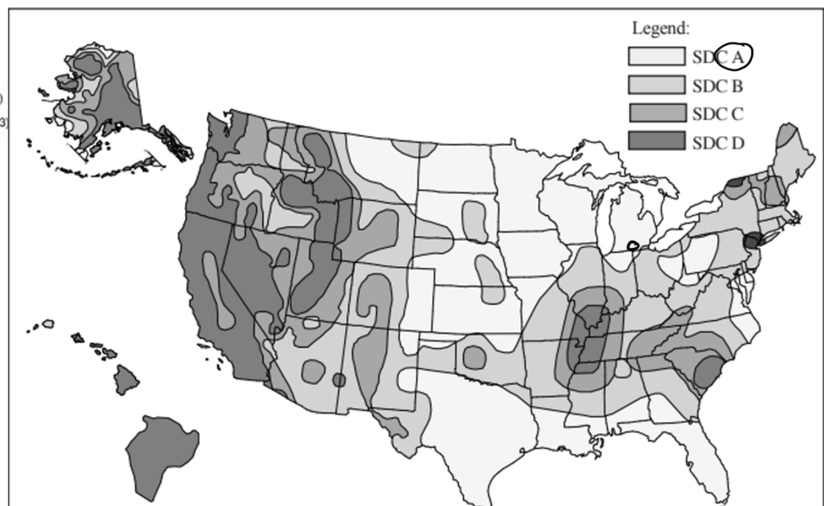
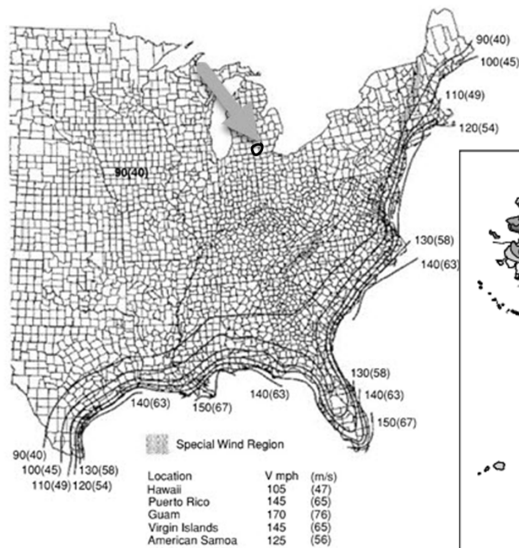

Figure 1—Seismic Design Categories for Site Class D, Seismic Use Group I and II, for a 0.2-Second Spectral Response Acceleration

Empirical Design Example

Checks:

Maximum height – table 1

MAX HEIGHT
TABLE 1 10' ✓

H/e (TABLE 2)
 $\frac{120''}{8} = 15 < 18$ ✓

MAX. UNREINF. HEIGHT
TABLE 3 → 10' < 12' ✓

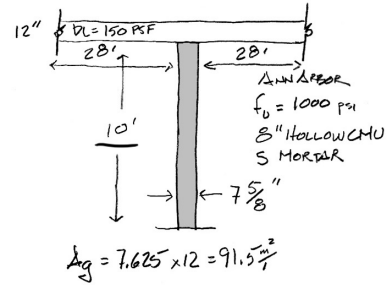

Masonry wall type:	Building height, h, ft (m)	Basic wind speed, w, mph (m/s)			
		w ≤ 90 (w ≤ 40)	90 < w ≤ 100 (40 < w ≤ 45)	100 < w ≤ 110 (45 < w ≤ 49)	110 < w (49 < w)
Part of the lateral force-resisting system	h ≤ 35 (11)	Allowed			Not allowed
Interior, not part of the lateral force-resisting system, in buildings other than enclosed ^A	h > 180 (55)	Not allowed			
	60 (18) < h ≤ 180 (55)	Allowed	Not allowed		
	35 (11) < h ≤ 60 (18)	Allowed	Not allowed		
Exterior, not part of the lateral force-resisting system	h > 180 (55)	Not allowed			
	60 (18) < h ≤ 180 (55)	Allowed	Not allowed		
	35 (11) < h ≤ 60 (18)	Allowed	Not allowed		
Exterior	h ≤ 35 (11)	Allowed			Not allowed

^A Per *Minimum Design Loads for Buildings and Other Structures*, ASCE 7 (ref. 4).

TEK 14-8B © 2008 National Concrete Masonry Association (replaces TEK 14-8A)

University of Michigan, TCAUP

Masonry

Slide 37 of 39

Empirical Design Example

Checks:

Minimum bracing – table 2

Maximum unreinforced height - table 3

MAX HEIGHT
TABLE 1 10' ✓

H/e (TABLE 2)
 $\frac{120''}{8} = 15 < 18$ ✓

MAX. UNREINF. HEIGHT
TABLE 3 → 10' < 12' ✓

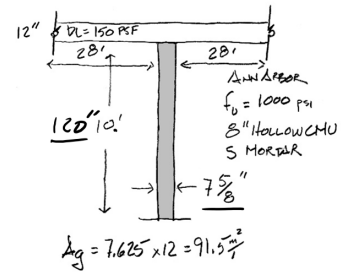

Table 2—Wall Lateral Support Requirements (ref. 1)		Table 3—Maximum Unreinforced Wall Spans, ft (m) ^A				
Construction (unreinforced)	Maximum wall length-to-thickness or height-to-thickness ratio ^A	Wall thickness, in. (mm)	6 (152)	8 (203)	10 (254)	12 (305)
Bearing walls						
Solid units or solid grouted	20	Solid or solid grouted	10 (3.0) ^B	13 (4.1)	16.6 (5.1)	20 (6.1)
All others	18	All other	9 (2.7) ^B	12 (3.7)	15 (4.5)	18 (5.5)
Nonbearing walls		Nonbearing walls				
Exterior	18	Exterior	9 (2.7)	12 (3.7)	15 (4.5)	18 (5.5)
Interior	36	Interior	18 (5.5)	24 (7.3)	30 (9.1)	36 (11)
Cantilever walls ^B		Cantilever Walls ^C				
Solid	6	Solid	3 (0.9)	4 (1.2)	5 (1.5)	6 (1.8)
Hollow	4	Hollow	2 (0.6)	2.6 (0.8)	3.3 (1.0)	4 (1.2)
Parapets (8-in. (203-mm) thick min.) ^B	3	Parapets ^C	1.5 (0.5)	2 (0.6)	2.5 (0.8)	3 (0.9)

^A Note that Ref. 6 includes modified requirements for walls with openings.

University of Michigan, TCAUP

Masonry

Slide 38 of 39

Empirical Design Example

Find allowable stress – table 4

Find load

$$P = F A_g$$

Calculate per foot using gross Area

f_u psi (Mpa)

f'_m psi (Mpa)

Hollow Unit Masonry (Units Complying With ASTM C 90-06 or Later) (ref. 6) ^C :		
	Type M or S	Type N
Hollow loadbearing CMU, $t \leq 8$ in mortar		
	2,000 (14) or greater	140 (0.97) 120 (0.83)
	1,500 (10)	115 (0.79) 100 (0.69)
F_u	1,000 (6.9)	f'_m 75 (0.52) 70 (0.48)
	700 (4.8)	60 (0.41) 55 (0.38)
Hollow loadbearing CMU, 8 in. $< t < 12$ in. (203 to 305 mm) ^D :		
	2,000 (14) or greater	125 (0.86) 110 (0.76)
	1,500 (10)	105 (0.72) 90 (0.62)
	1,000 (6.9)	65 (0.49) 60 (0.41)
	700 (4.8)	55 (0.38) 50 (0.35)
Hollow loadbearing CMU, $t \geq 12$ in (305 mm) ^D :		
	2,000 (14) or greater	115 (0.79) 100 (0.69)
	1,500 (10)	95 (0.66) 85 (0.59)
	1,000 (6.9)	60 (0.41) 55 (0.38)
	700 (4.8)	50 (0.35) 45 (0.31)
Hollow walls (noncomposite masonry bonded) ^B :		
	$t \leq 8$ in. (203 mm) ^D	75 (0.52) 70 (0.48)
	$8 < t < 12$ in (203 to 305 mm) ^D	70 (0.48) 65 (0.45)
	$t \geq 12$ in (305 m.m) ^D	60 (0.41) 55 (0.38)

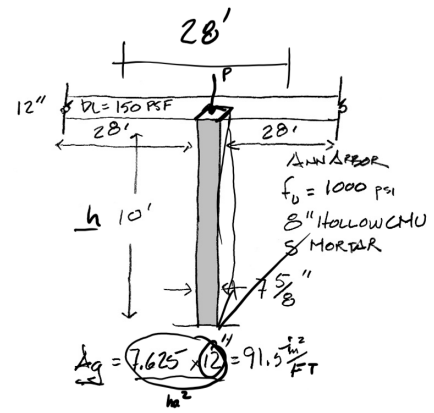

TABLE 4 Hollow 8" $f_u = 1000$

TYPE S $\rightarrow 75 \text{ PSI}$

$$P = F A_g = 75 (7.625 \times 12) \text{ PLF}$$

$$\Rightarrow 6862.5 \text{ PLF}$$

TRIBUTARY STRIP = 28'

PLF

$$P = 6862 = DL(28') + LL(28')$$

$$6862 = 150(28) + \overline{LL}(28)$$

$$LL = \underline{95 \text{ PSF CAPACITY}}$$