

# Clay Masonry

- Brick Production
- Size and Application
- Performance
- Details
- Clay Tile

Monadnock Building  
Burnham & Root  
1891-1893



## Monadnock Building

- Chicago
- 1891 – 1893
- Burnham & Root



# Monadnock Building

Burnham & Root  
1892, Chicago  
215 ft., 16 stories

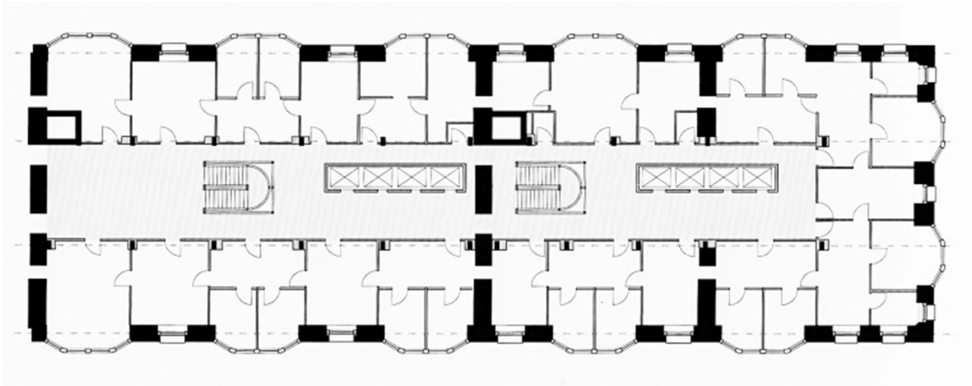

University of Michigan, TCAUP

Masonry

Slide 3 of 44

# Monadnock Building

- Chicago
- Architect: Burnham & Root
- 1891-1893
- 16 stories - 215 feet
- tallest load-bearing brick building

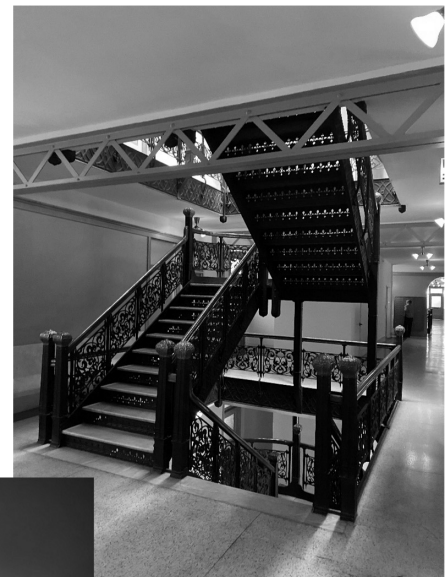

Addison Lentz

University of Michigan, TCAUP

Masonry

Slide 4 of 34

# Monadnock Building

- Chicago
- Architect: Burnham & Root
- 1891-1893
- 16 stories - 215 feet
- tallest load-bearing brick building



Addison Lentz

# Monadnock Building

- Chicago
- Architect: Burnham & Root
- 1891-1893
- 16 stories - 215 feet
- tallest load-bearing brick building

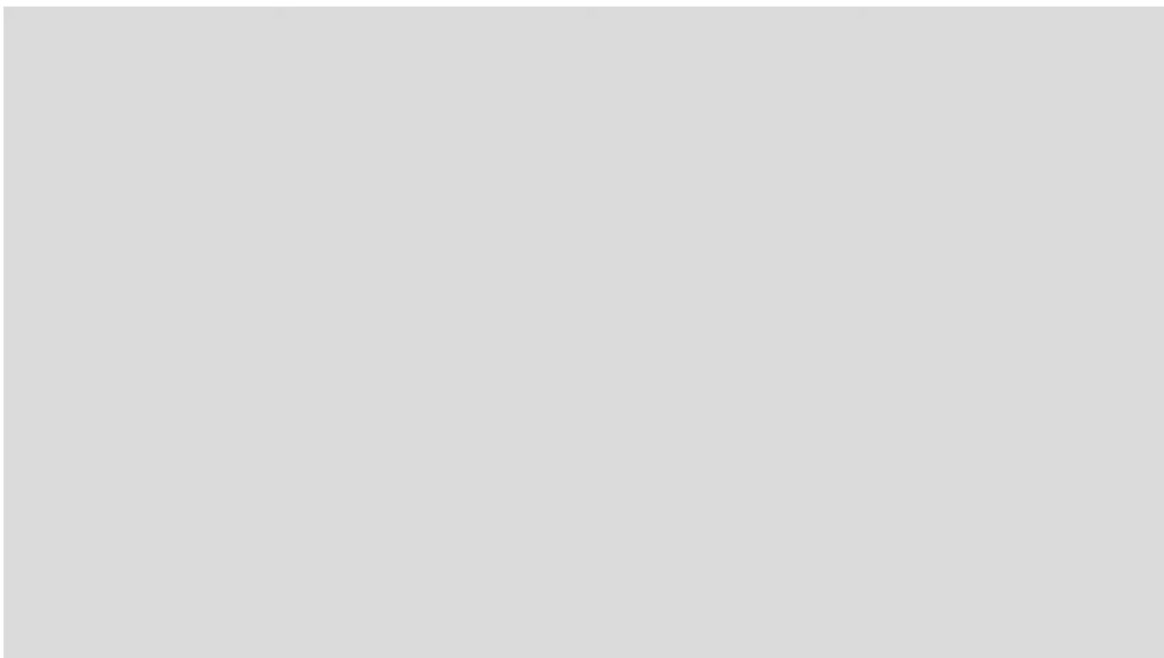

# Monadnock Building

Tony Fitzpatrick, Arup (from *Tower without Ends - Tour Sans Fins*)

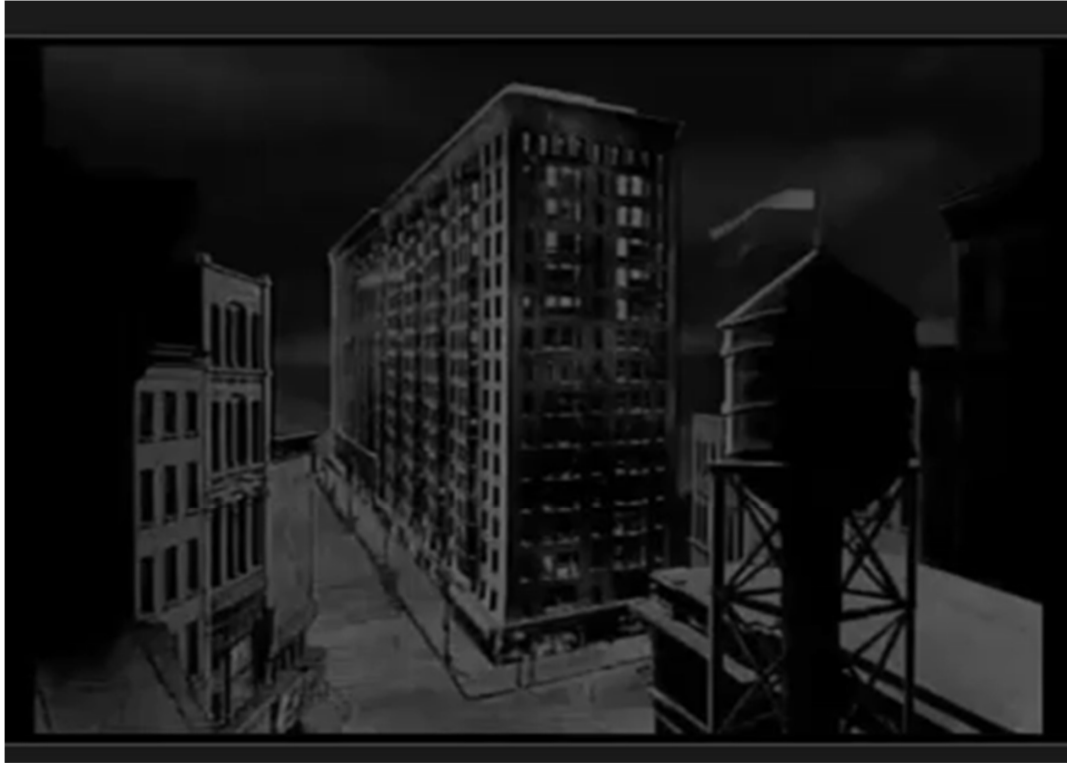

## Clay Units – Brick & Tile

### Nomenclature

Six positions in a wall

- Stretcher
- Header
- Rowlock stretcher
- Rowlock
- Soldier
- Sailor

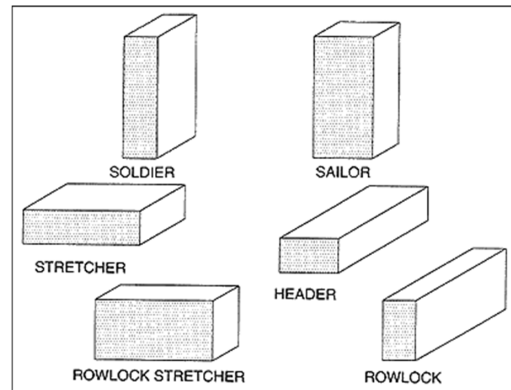

### Sizes

- 8 inch grid
- 3/8 inch mortar joint

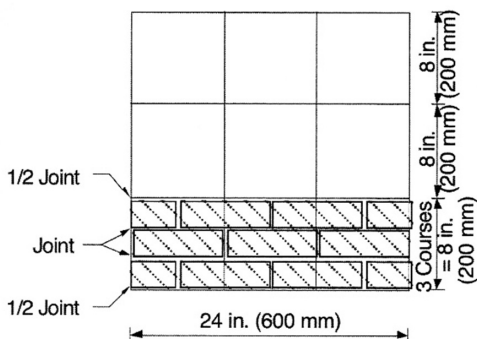

### 3/8" Mortar Joint Between Bricks (Most Common)

BRICK TYPE	SPECIFIED SIZE D X H X L (INCHES)	NOMINAL SIZE D X H X L	VERTICAL COURSE
Standard	3 5/8 x 2 1/4 x 8	Not modular	3 courses = 6"
Modular	3 5/8 x 2 1/4 x 7 5/8	4 x 2 2/3 x 8	3 courses = 6"
Norman	3 5/8 x 2 1/4 x 11 5/8	4 x 2 2/3 x 12	3 courses = 6"
Roman	3 5/8 x 1 5/8 x 11 5/8	4 x 2 x 12	1 course = 2"
Jumbo	3 5/8 x 2 3/4 x 8	4 x 3 x 8	1 course = 3"
Economy	3 5/8 x 3 5/8 x 7 5/8	4 x 4 x 8	1 course = 4"
Engineer	3 5/8 x 2 13/16 x 7 5/8	4 x 3 1/5 x 8	5 courses = 16"
King	2 3/4 x 2 5/8 x 9 5/8	Not modular	5 courses = 16"
Queen	2 3/4 x 2 3/4 x 7 5/8	Not modular	5 courses = 16"
Utility	3 5/8 x 3 5/8 x 11 5/8	4 x 4 x 12	1 course = 4"

# Clay Units – Brick & Tile Solid vs. Hollow

- Solid < 25% void Hollow > 25% void
- Gross area from outer dimensions
- Net area is minus the voids
- Core is a void < 1.5 inches
- Cell is a void > 1.5 inches
- Frog is a depression
- Ears are extensions at ends

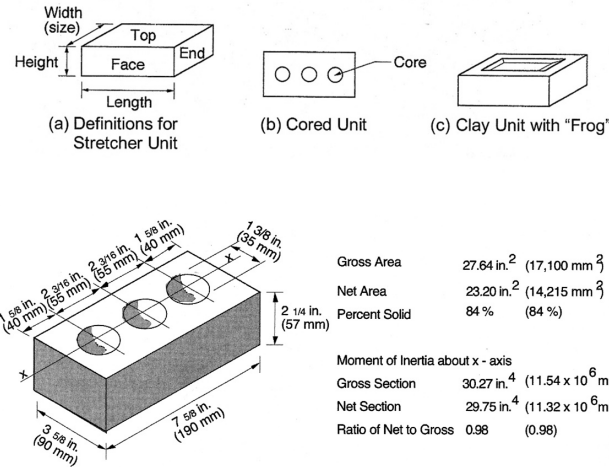
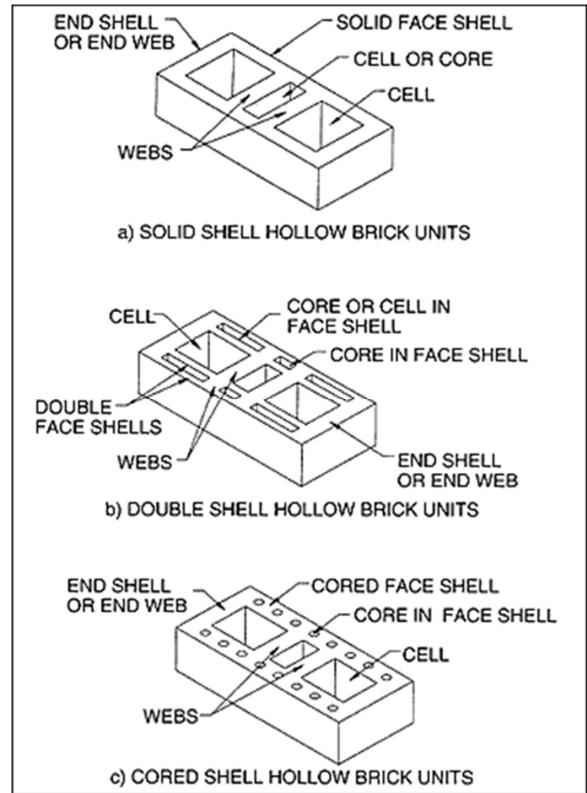

Figure 4.3 Effect of percent solid on section properties of clay masonry units.



# Clay Units – Brick & Tile

## Brick bond patterns

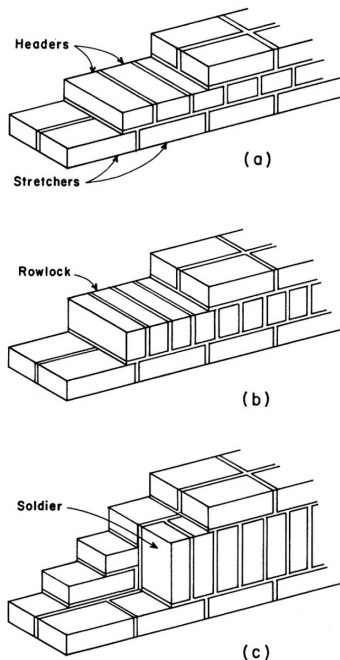
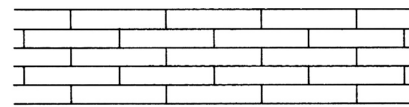
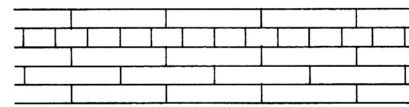

FIGURE 4.2. Ordinary positions for bricks.



running bond



common bond

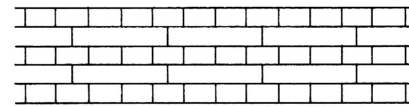

English bond

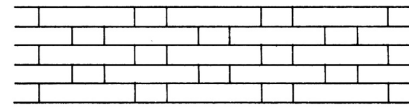

Flemish bond

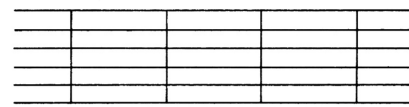

stack bond

# Clay Units – Brick & Tile

## Mortar joint types

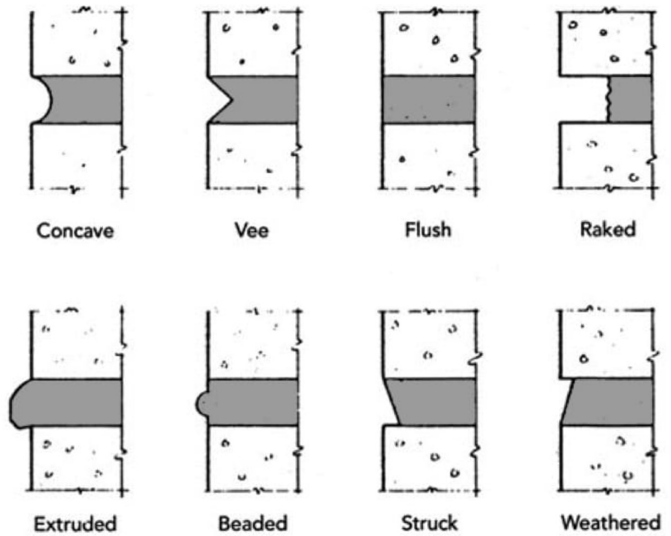
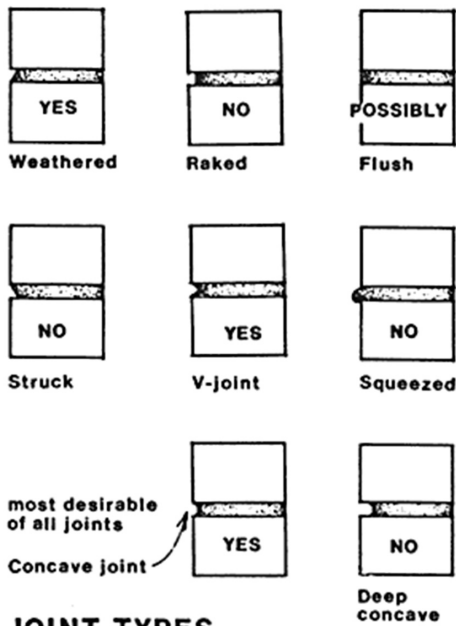

Architectural types

Considering moisture penetration

# Clay Units – Manufacture

## Ingredients

- Surface clays
- Shale clays
- Fire clays

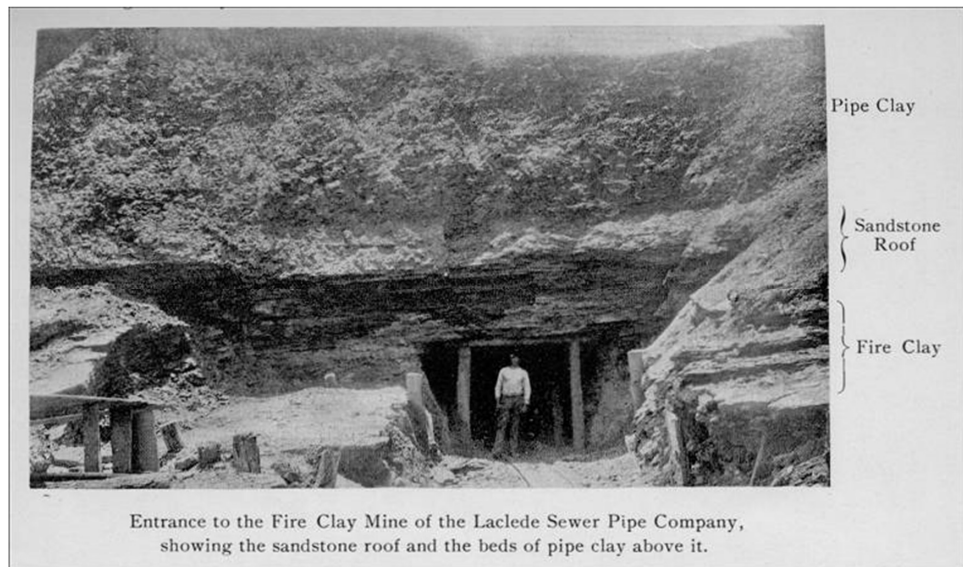

# Clay Units – Manufacture

## Ingredients

- Surface clays
- Shale clays
- Fire clays

## Preparation

- Mine
- Crush
- Moisturize and mix (pug mill)

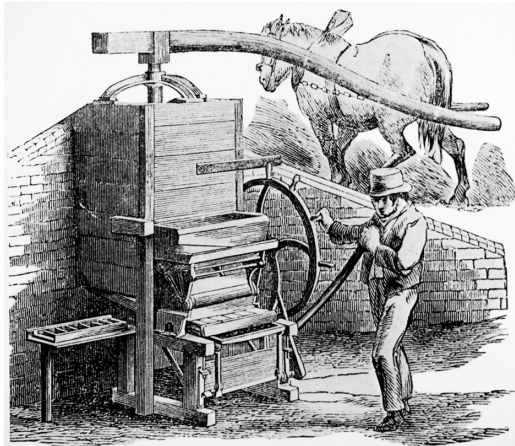

University of Michigan, TCAUP

Masonry

Slide 13 of 34

# Clay Units – Manufacture

## Shaping

- Molded
- Extruded

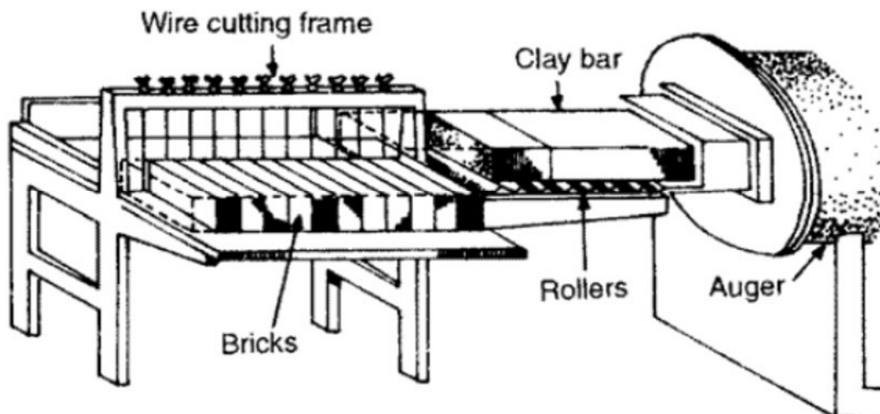
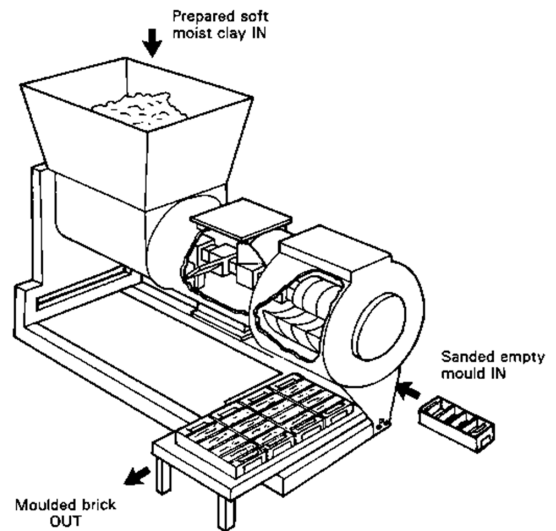

University of Michigan, TCAUP

Masonry

Slide 14 of 34

# Clay Units – Manufacture

## Shaping

- Molded
- Extruded



# Clay Units – Manufacture

## Shaping

- Molded
- Extruded

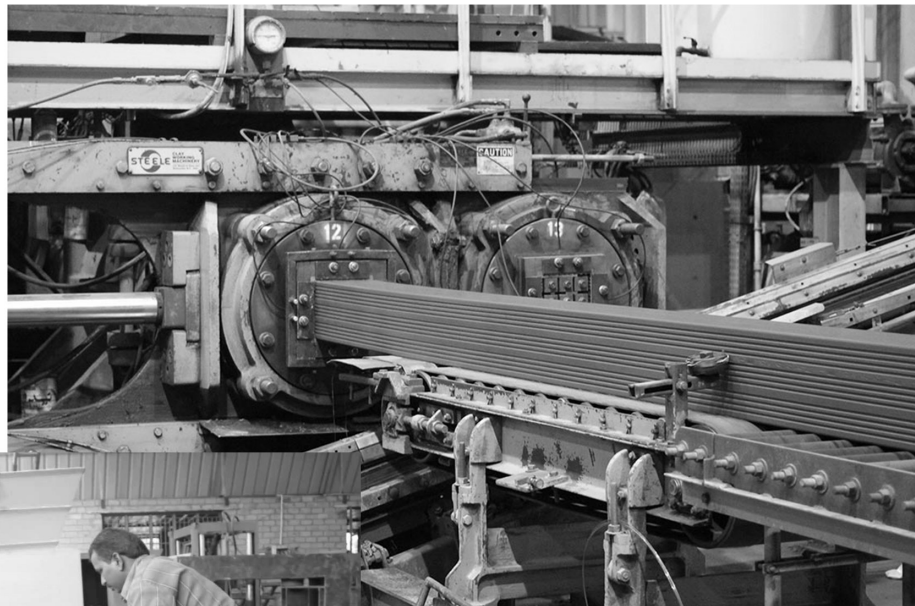

# Clay Units – Manufacture

## Process

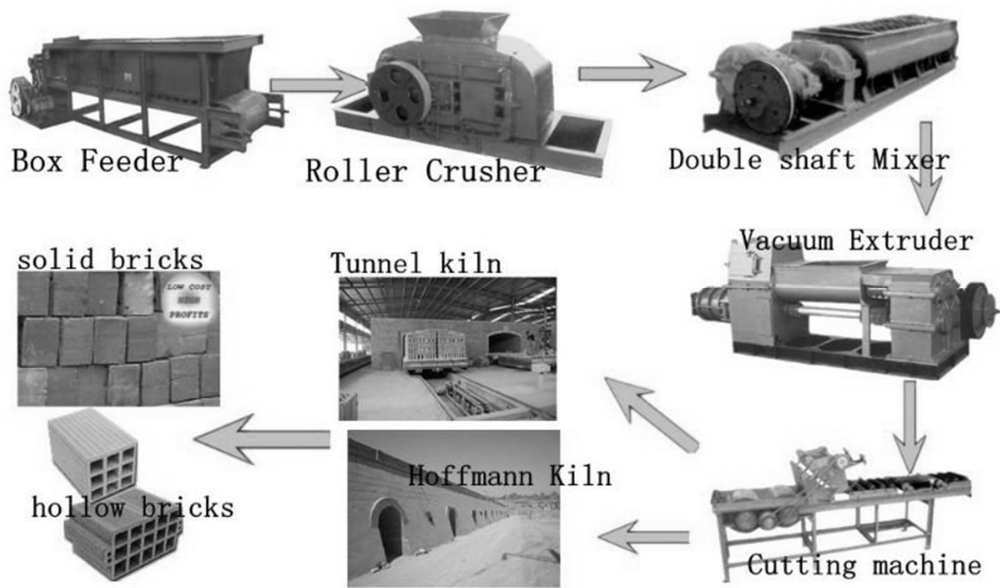

# Clay Units – Manufacture

## Kilns

- Beehive
- Tunnel

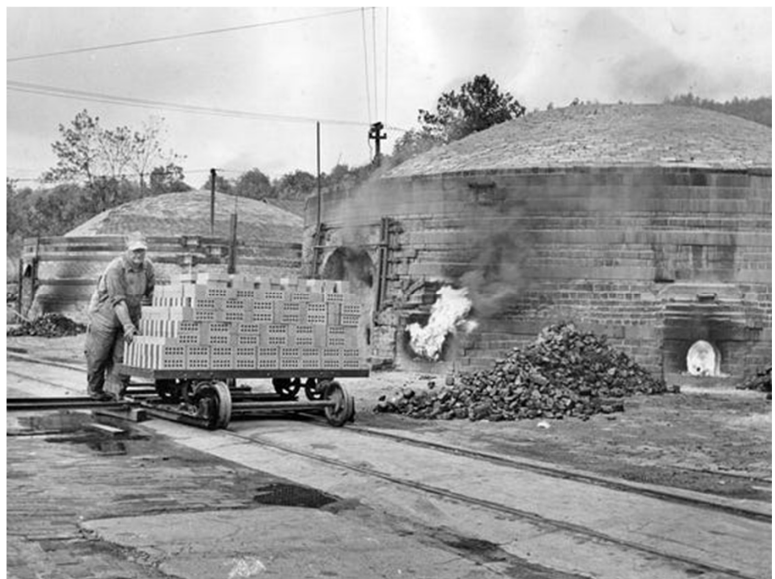

# Clay Units – Manufacture

## Kilns

- Beehive
- Tunnel

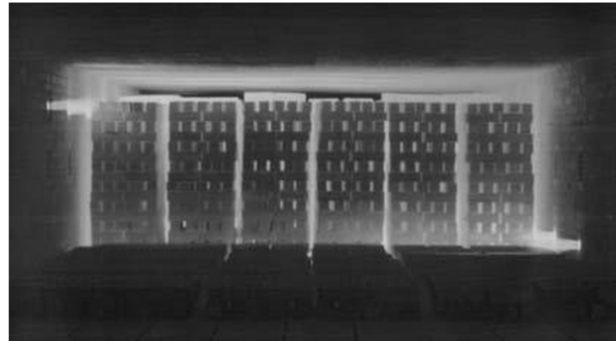

# Clay Units – Performance

## Grades

- SW – severe weather
- MW – moderate weather
- NW – no weather
- LBX – frost
- LB – no frost

## Absorption C/B

- B – 5 hr boiling water
- C – cold water 24 hr
- C/B - ratio

**Table 4.1** Physical Requirements for Solid and Hollow Brick (from Ref. 4.10 and 4.12)

Brick grade	Minimum compressive strength* psi (MPa)		Maximum water absorption by 5-hour boiling (%)		Maximum saturation coefficient (C/B)	
	Average of 5 bricks	Individual	Average of 5 bricks	Individual	Average of 5 bricks	Individual
SW	3000 (20.7)	2500 (17.2)	17	20	0.78	0.8
MW	2500 (17.2)	2200 (15.2)	22	25	0.88	0.9
NW**	1500 (10.3)	1250 (8.6)	No limit	No limit	No limit	No limit

\* Based on gross area for solid units and net area for hollow units.  
 \*\* Not applicable to hollow or facing brick.

**Table 4.2** Physical Requirements for Clay Loadbearing Wall Tile (from Ref. 4.12)

Grade	Minimum compressive strength*, psi (MPa)				Maximum water absorbed by 1-hour of boiling, %	
	End construction tile		Side construction tile		Average of 5 specimens	Individual
	Average of 5 specimens	Individual	Average of 5 specimens	Individual		
LBX	1400 (9.6)	1000 (6.8)	700 (4.8)	500 (3.4)	16	19
LB	1000 (6.8)	700 (4.8)	700 (4.8)	500 (3.4)	25	28

\* Based on gross area

# Clay Units – Compression

## Compressive Strength

- By grade (SW, MW, NW – Tab. 4.1)
- Clay type (surface, shale, fire)
- Forming (molded, extruded)

## Typical minimum in US

- 8000 psi

Grade	Minimum compressive strength (psi)	
	Gross Area	
	Average of 5	Individual
SW	3000	2500
MW	2500	2200

Type	Average strength (psi)
All molded	5290
Extruded, All	11300
Extruded, Fireclay	15350
Extruded, Shale	11260
Extruded, Other	9170

# Clay Units – Tension

## Tensile Strength

- Direct tension (difficult)
- Modulus of Rupture (beam – high value)
- Splitting Tension (easier to do)
- ratio of tension/compression stress ~0.10

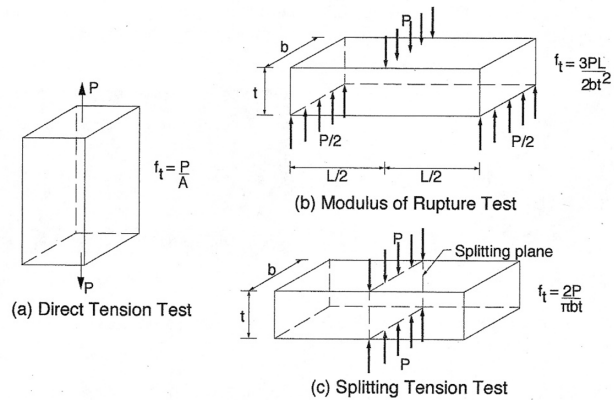

Figure 4.6 Tension test methods.

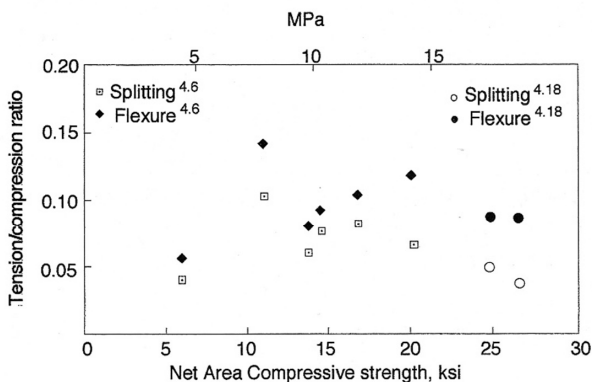
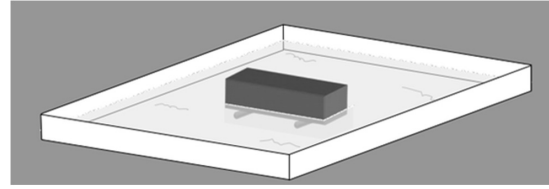

Figure 4.15 Tensile strength of clay masonry units.

# Clay Units – Water Absorption

## Initial Rate of Absorption (IRA)

- Affects mortar and brick bond
- If too high – sucks water out of mortar too fast and weakens the mortar bond
- If too low – does not bond to brick



## IRA test

- Oven dry brick for 24 hrs
- Cool down
- Get dry weight:  $W_{\text{DRY}}$  grams
- Place in 1/8" water for 1 min
- Dab dry with towel
- Get wet weight:  $W_{\text{WET}}$  grams
- Water gain is:  $W_{\text{GAIN}} = W_{\text{WET}} - W_{\text{DRY}}$
- 5 bricks should be tested.

$$\text{IRA} = \frac{30 \times W_{\text{GAIN}}}{\text{AREA}_{\text{NET}}} \text{ gr/min/30in}^2$$

## Application

- Ideal range is between 5 and 20
- If  $\text{IRA} > 30$ , then wet units before placing
  - 24 hrs before placement
  - Surface should not be wet when used
- Field test:
  - Place 20 drops of water on quarter sized area
  - If all water is absorbed within 90 sec. then wetting the brick is recommended.

# Clay Units – Water Absorption

## Absorption Properties

- Rate at which water is absorbed
- Can be a measure of porosity and durability

## C/B Ratio

- C: cold water absorption in 24 hrs (free absorption)
- B: additional water absorbed in 5 hrs of boiling. A measure of the remaining pore space.
- The more remaining pore space (lower C/B), the more durable the brick. More pore space to absorb freezing expansion.



## Application

- The lower the C/B ratio, the more durable the brick.
- There is also a limit on the boiling test:
  - Grade SW:  $C/B < 0.78$  AND  $B < 17\%$
  - Grade MW:  $C/B < 0.88$  AND  $B < 22\%$



# Clay Units – Durability

## Durability – freeze/thaw

- By grades – SW, MW
- C/B limit
- 24 hr cold  $\leq$  8%
- 50 freeze/thaw cycles
- Pore size  $>$  3 microns (proposed)

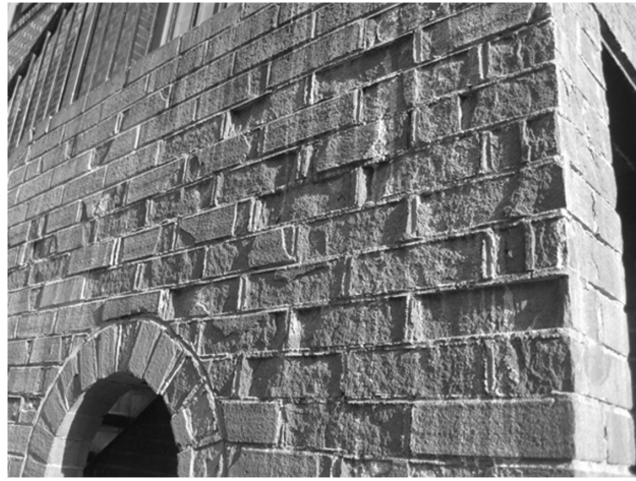

# Clay Units – Efflorescence

## Efflorescence on brick

- Leaching of salts to surface
- Initially cleaned off with muriatic acid (diluted)
- If it returns there may be a moisture problem
- Can lead to spalling



# Clay Units – Expansion

## Moisture Expansion

- $k_e = 3 \times 10^{-4}$  in./in. (mean value)

## Thermal Expansion

- $k_t = 3.9 \times 10^{-6}$  in./in./F (mean value)
- For:
- 3/8 in. expansion joint
- 50% extensibility
- $\Delta t = 100$  F
- Joint spacing = 22 ft.

$$S_e = \frac{w_j e_j}{(k_e + k_t \Delta t) 100}$$

$S_e$  = spacing of expansion joints

$w_j$  = width of expansion joint

$e_j$  = extensibility of expansion joint material (%)

## Construction Detailing

- Keep joint free of foreign material that would prevent compression, e.g. mortar
- Interrupt any joint reinforcing

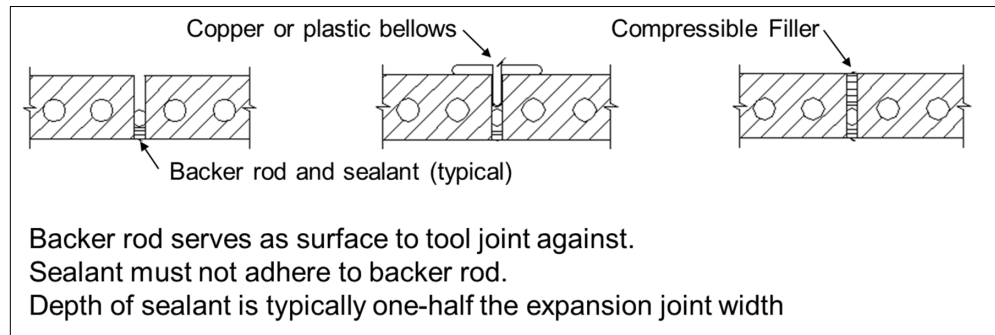

# Horizontal Expansion Joint

## Construction Detailing

- Place below shelf angle
- Brick expansion
- Frame shortening
- Shelf angle deflection

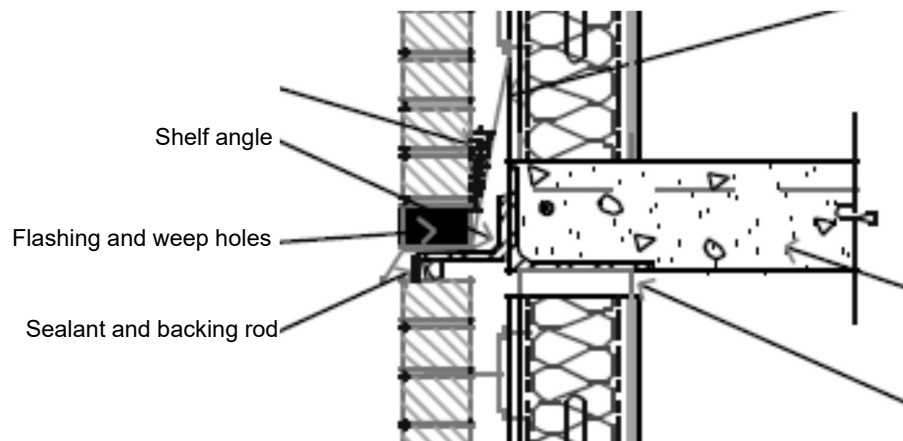

# Horizontal Expansion Joint

## Construction Detailing

- Place below shelf angle
- Brick expansion
- Frame shortening
- Shelf angle deflection

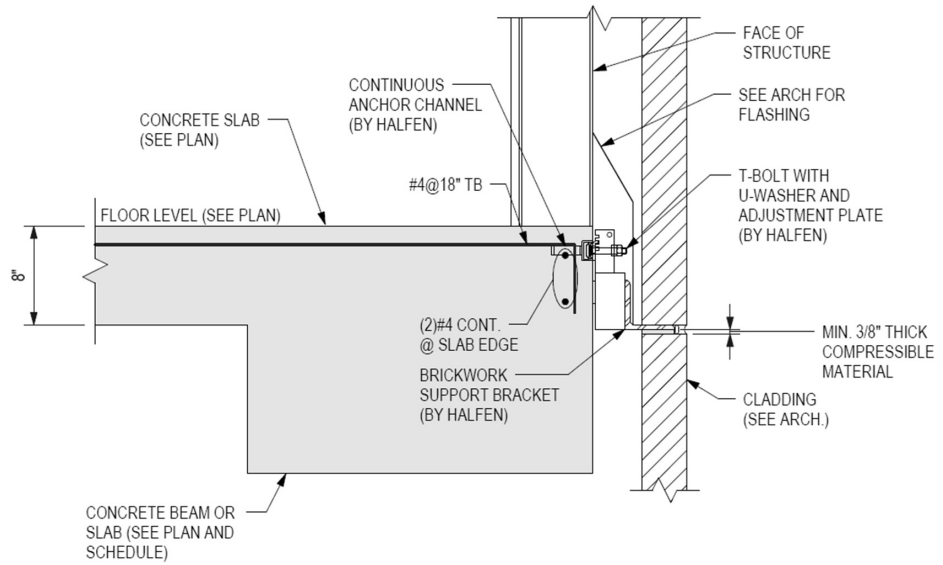

**10** TYPICAL HALFEN BRICK SUPPORT  
NOT TO SCALE

# Clay Units – Performance

Required Net Area Compressive Strength of Clay Masonry Units (psi)		$f'_m$ For Net Area Compressive Strength of Masonry (psi)
When Used With Type M or S Mortar	When Used With Type N Mortar	
1,700	2,100	1,000
3,350	4,150	1,500
4,950	6,200	2,000
6,600	8,250	2,500
8,250	10,300	3,000
9,900	--	3,500
11,500	--	4,000

(From Masonry Standards Joint Committee Specifications for Masonry Structures, ACI 530.1/ASCE 6/TMS 602-99)

# Clay Units – Performance

## Typical Values

Property		Clay Masonry	Concrete Masonry
Unit strength		8000 <i>psi</i>	2000 <i>psi</i>
Type N mortar	$f'_m$	2440 <i>psi</i>	1750 <i>psi</i>
	$E_m$	$1.70 \times 10^6$ <i>psi</i>	$1.58 \times 10^6$ <i>psi</i>
Type M or S mortar	$f'_m$	2920 <i>psi</i>	2000 <i>psi</i>
	$E_m$	$2.05 \times 10^6$ <i>psi</i>	$1.80 \times 10^6$ <i>psi</i>

Property	Clay Masonry	Concrete Masonry
Modulus of Elasticity, $E_m$	$700f'_m$	$900f'_m$
Shear Modulus, $G$	$0.4E_m$	$0.4E_m$
Coefficient of Creep	$\frac{0.7 \times 10^{-7}}{\text{psi}}$	$\frac{2.5 \times 10^{-7}}{\text{psi}}$

## Clay Tile

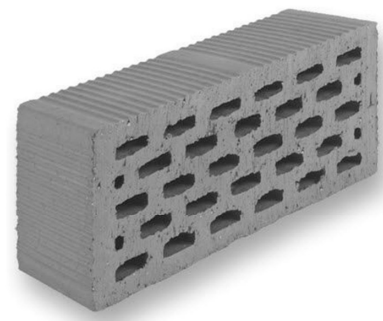
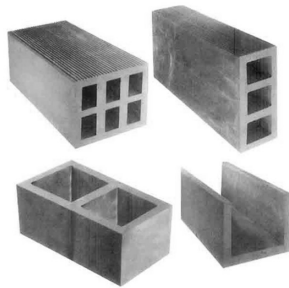

## Insulated Clay Tile

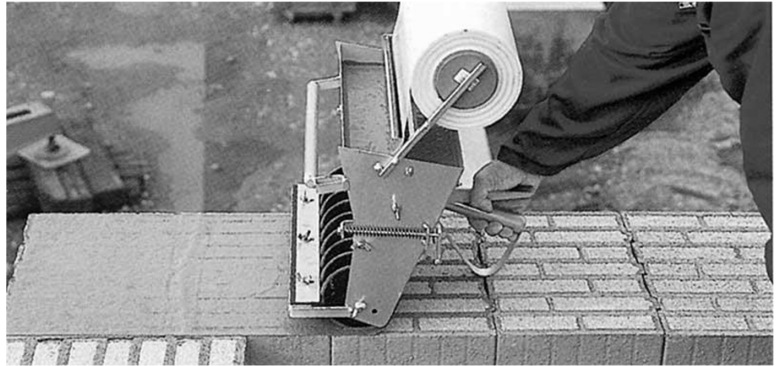
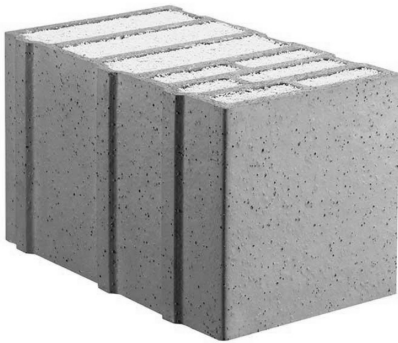
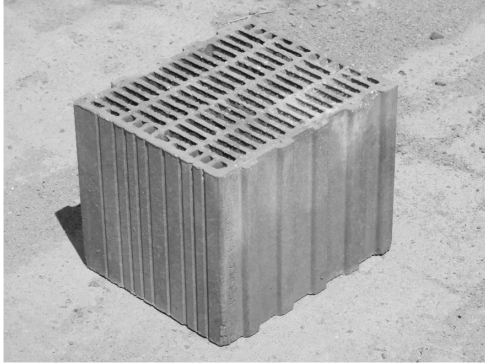

University of Michigan, TCAUP

Structures II

Slide 33 of 34

## Insulated Clay Tile

**Mauerwerk errichten**

**UNIPOR**

**Mauertec - Verfahren**

University of Michigan, TCAUP

Structures II

Slide 34 of 34