

History part 3

Masonry shells and vaults

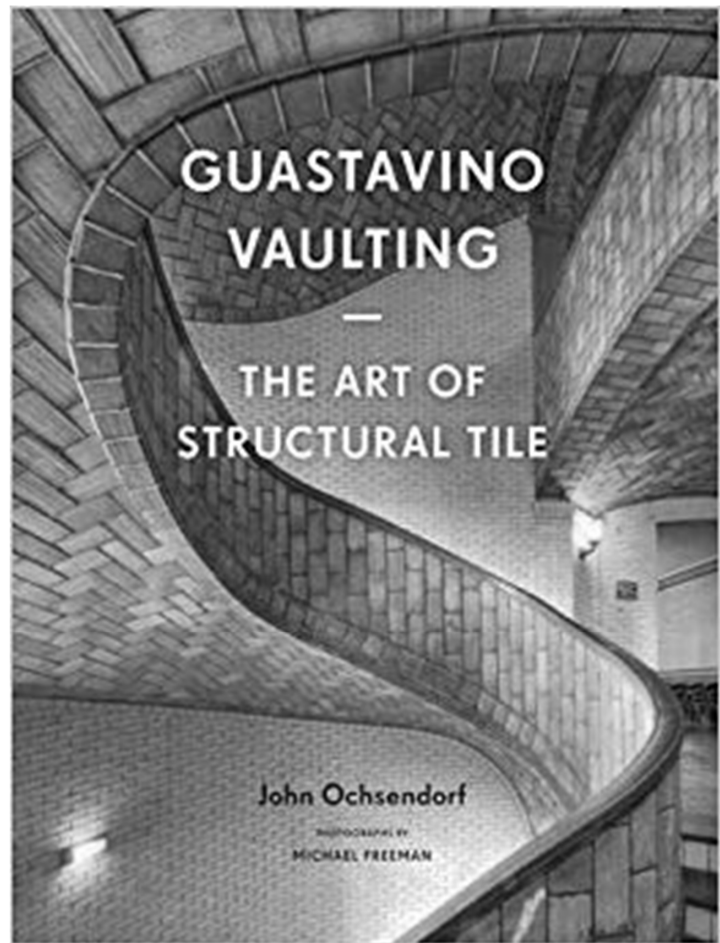

Barrel vaults

with formwork
without formwork

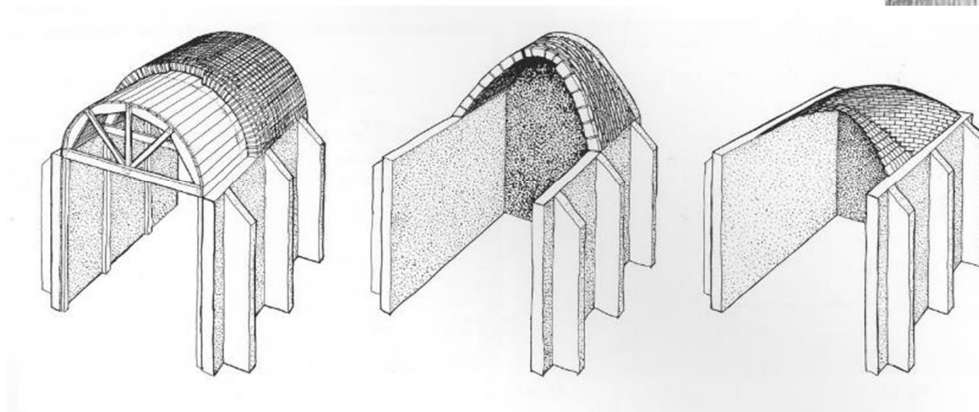
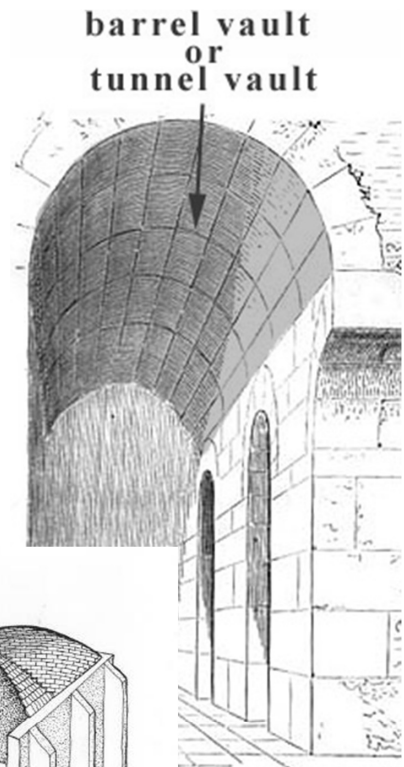

Barrel vaults

with formwork
Senegal, Africa

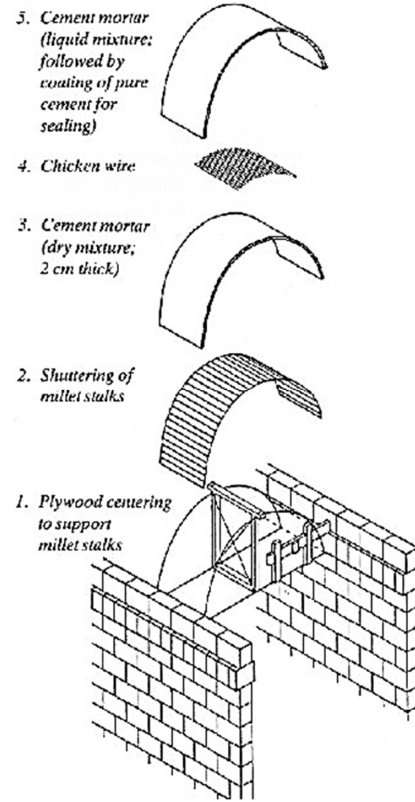
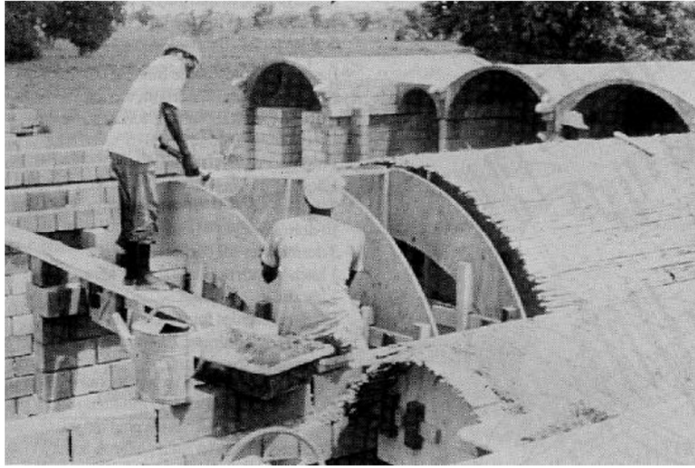

Barrel vaults

without formwork
Senegal, Africa



Thin Masonry Domes

with formwork
Santo Domingo De Guzman Church
Oaxaca, Mexico

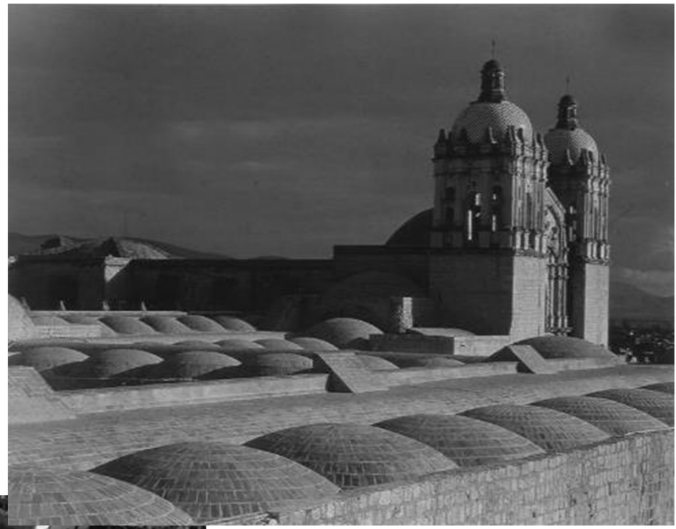

University of Michigan, TCAUP

Masonry

Slide 5 of 35

Thin Masonry Domes

with formwork
Santo Domingo De Guzman Church
Oaxaca, Mexico



University of Michigan, TCAUP

Masonry

Slide 6 of 35

Thin Shell Masonry

without formwork
Antoni Gaudi
Park Güell, Barcelona



University of Michigan, TCAUP

Masonry

Slide 7 of 35

Thin Shell Masonry

without formwork
Antoni Gaudi
Park Güell, Barcelona

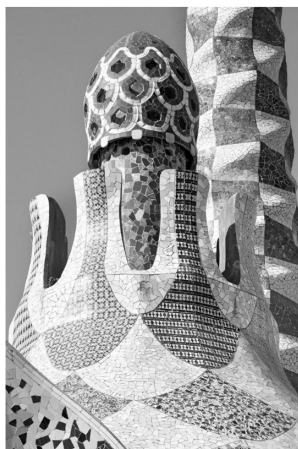

University of Michigan, TCAUP

Masonry

Slide 8 of 35

Thin Shell Masonry

without formwork
Antoni Gaudi
Casa Milà, Barcelona



University of Michigan, TCAUP

Masonry

Slide 9 of 35

Thin Shell Masonry

without formwork
Antoni Gaudi
Casa Milà, Barcelona

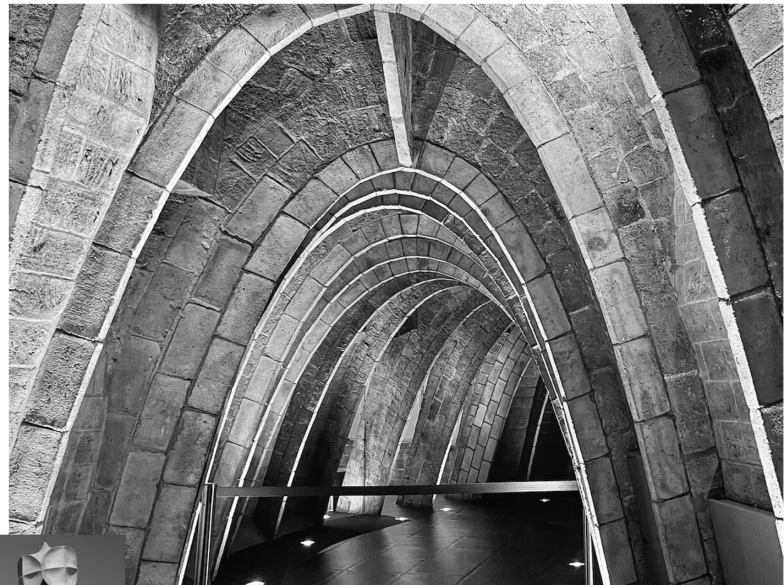

University of Michigan, TCAUP

Masonry

Slide 10 of 35

Floor Arches

Chicago, 1872 - 1884

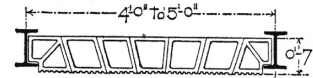
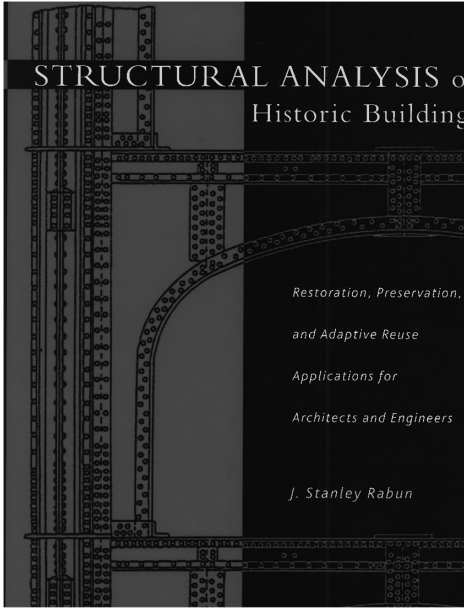

Figure 4-33. Terra cotta flat arch: Equitable Building, Chicago, 1872. (From Freitag 1909, 9.)

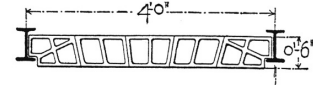

Figure 4-34. Flat arches: Montauk Building, Chicago, 1881. (From Freitag 1909, 9.)

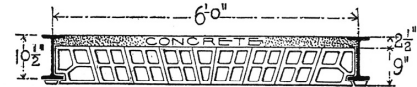

Figure 4-35. Terra cotta arch: Home insurance Building, Chicago, 1884. (From Freitag 1909, 9.)

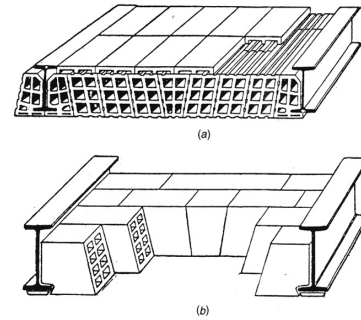

Figure 4-36. Types of terra cotta elements: (a) side construction terra cotta arch; (b) end construction terra cotta arch. (From Freitag 1909, 97, 99, 101.)

Floor Arches

US textbooks, 1905 - 1909

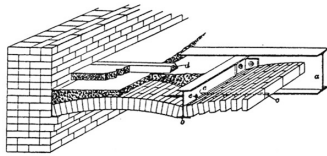

Figure 4-31. Details of brick arch fireproof floor. (From International Correspondence Schools 1905, para. 22, 15.)

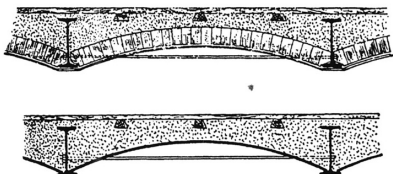

Figure 4-32. Brick arch and corrugated iron arch. (From Freitag 1909, 90.)

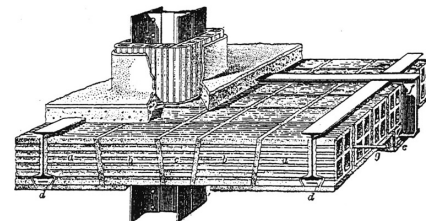
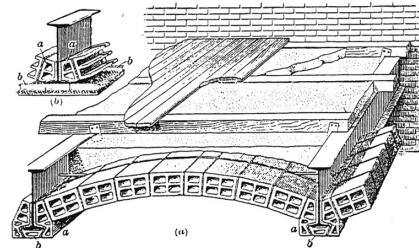
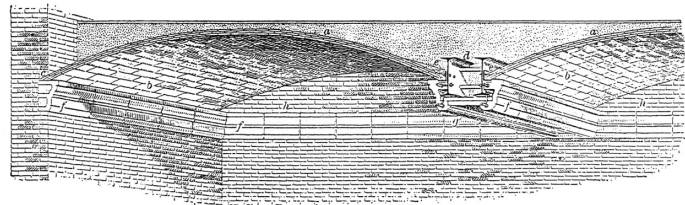
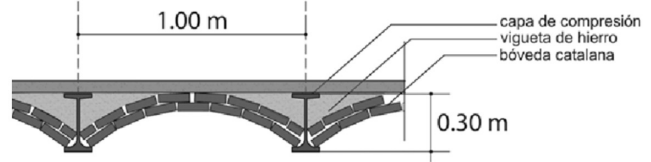
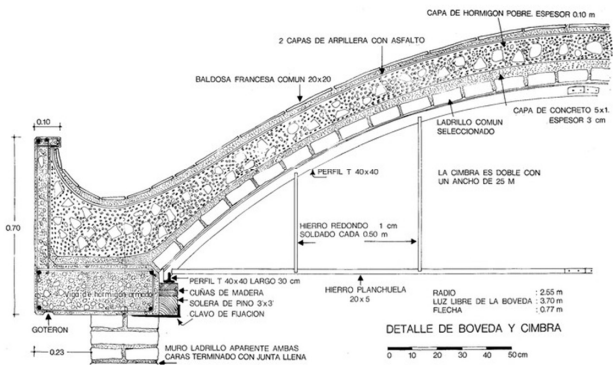
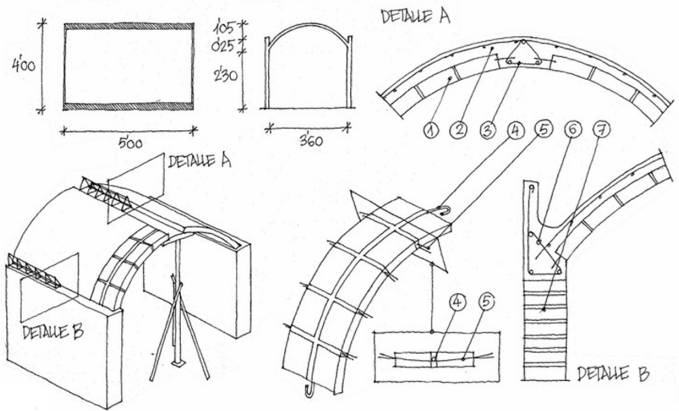
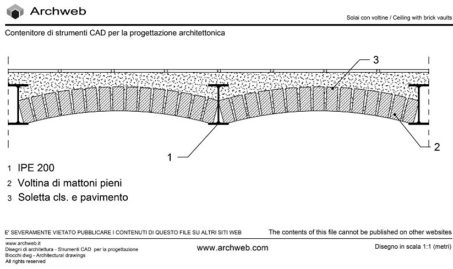

Figure 4-40. Miscellaneous details: fireproof floor systems; terra cotta arches. International Correspondence Schools 1905B, para. 22, 21.

Reinforced Masonry Shells

Eladio Dieste, Uruguay

- ① COSTILLOS DE FÁBRICA ARMADAS
- ② CAPA CONTR. CON MLE. 20x15x4
- ③ CADENA TRIANGULAR 3Ø8, Cc Ø4 A 20
- ④ ARMADO LONGITUDINAL 1Ø6/COSTILLO
- ⑤ ALAMBRE RECCIDO TRANSVERSAL
- ⑥ VIGA DE BORDE 3Ø8, Cc Ø4 A 20
- ⑦ MURO DE FÁBRICA 15 cm.



University of Michigan, TCAUP

Masonry

Slide 13 Of 35

Reinforced Masonry Shells

Eladio Dieste, Uruguay
Our Lady of Lourdes Church
1958

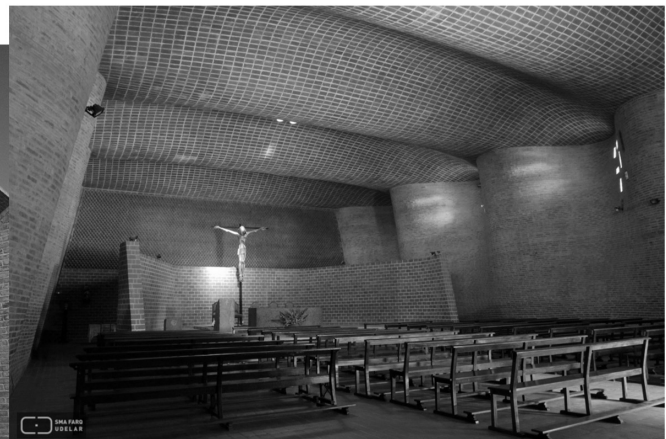

University of Michigan, TCAUP

Masonry

Slide 14 Of 35

Reinforced Masonry Shells

Eladio Dieste, Uruguay
Don Bosco School Gymnasium
1984



University of Michigan, TCAUP

Masonry

Slide 15 Of 35

Reinforced Masonry Shells

Eladio Dieste, Uruguay
Shopping Center, Montevideo
1984



University of Michigan, TCAUP

Masonry

Slide 16 Of 35

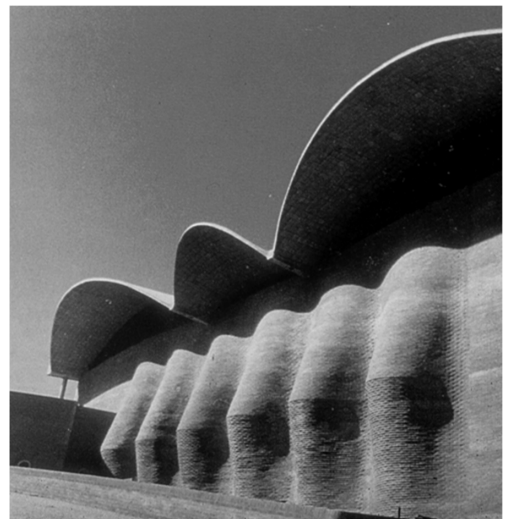

Guastavino Vaulting

Rafael Guastavino Moreno 1842 -1908
Guastavino Co. 1885 – 1962
Started in Boston



Grand Central Oyster Bar & Restaurant

University of Michigan, TCAUP

Masonry

Slide 17 Of 35

Guastavino Vaulting

Detroit Train Station, 1913



University of Michigan, TCAUP

Masonry

Slide 18 Of 35

Guastavino Vaulting

Guastavino Co. 1885 – 1962
Started in Boston

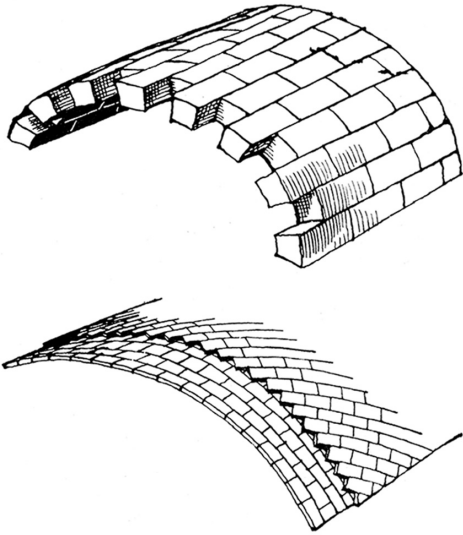

University of Michigan, TCAUP

Masonry

Slide 19 Of 35

Guastavino Vaulting

John Ochsendorf, MIT

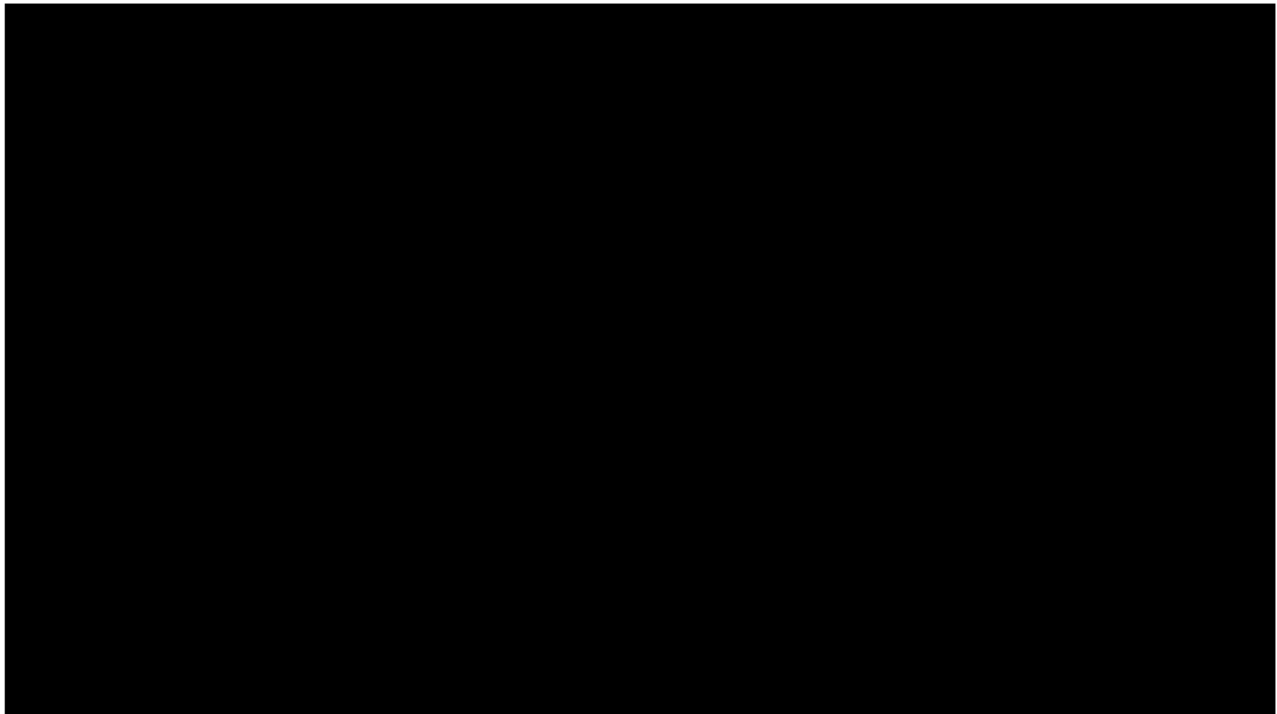

University of Michigan, TCAUP

Masonry

Slide 20 Of 35

Guastavino Vaulting

John Ochsendorf, MIT



University of Michigan, TCAUP

Masonry

Slide 21 Of 35

Guastavino Vaulting

John Ochsendorf, PINC, Sarasota 2015



University of Michigan, TCAUP

Masonry

Slide 22 Of 35

Initial Tile Design

Tile Pattern

In typical Guastavino domes the tiles are 2:1 and placed in herringbone-pattern courses. This pattern is helpful in layering because tiles will cover joints and prevent stacking. A similar pattern was used for this dome, but the shape of the tile was optimized based on its location on the surface of the dome.

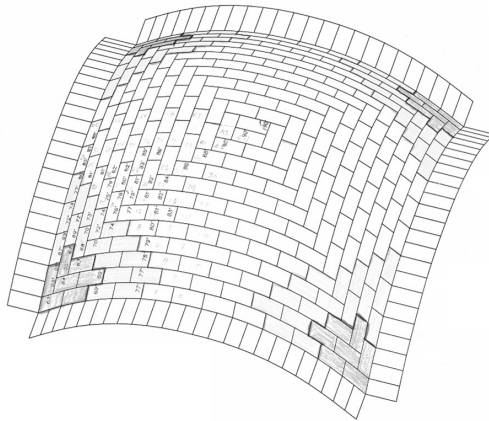

Dome with optimized tile geometry. Orange: 67° Green: 77° White 90°

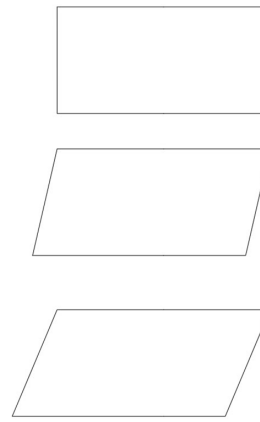

Top: 90° Middle: 77° Bottom: 67°

Tile Shape

The base corners of the dome started with 67° corner angle tiles. Then 77° corner angle tile were placed further up the dome corners. Finally, tiles with 90° corner angles were placed in the middle, and finished the top of the dome.



Herringbone-pattern in a Guastavino dome

Layer Orientation

The tile shape in the second layer utilized the same layout of tile geometries as the first layer. In order to create a structural dome using the Guastavino method a second layer was oriented 90° from the first layer. This covered up joints and prevented stacking in order to make a running bond. This helps prevent cracking and increases the capacity of the dome.

Tiles: Forming and Cutting

Clay Forming

The raw clay was taken from block form, divided, then rolled out to a uniform thickness. This was done by a clay slab roller, which utilizes a heavy roller to press the clay. Canvas sheets prevented the clay from sticking to the work surface and the roller. Scraps from tile cutting were able to be remolded and formed into new clay sheets.



Raw clay being divided



Clay slab roller making a uniform clay sheet



90° tiles being cut using wooden templates and cutting utensils



Tile Cutting

The tiles were cut out of the clay sheets using wooden templates and various cutting utensils. The wooden templates were used instead of a typical "cookie cutter" template to ensure the tiles would not stick to the template and subsequently deform. Three different size tiles were used: Tiles with 90° corner angles, 77° corner angles, and 67° corner angles.

Tiles: Drying and Kiln Firing

Tile Drying

After all the tiles were cut, they were then placed on a drying rack to air-dry prior to being placed in the kiln. After drying for roughly 24-48 hours, the tiles were then flipped to decrease warping. After being flipped, the tiles were air-dried for another 24-48 hours.

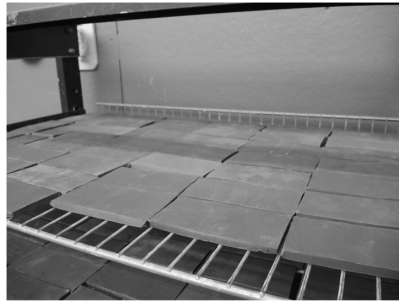

Clay tiles air-drying prior to being fired in the kiln.



Multiple sheets of clay tiles drying on a drying rack.



Kiln used for firing tiles.

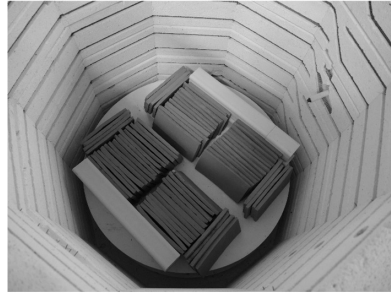

Tiles were stacked in multiple layers within the kiln.

Kiln Firing

After drying, the tiles were then placed in the kiln to be fired. Fired clay has substantially different properties than unfired clay. Additionally, the duration of firing effects the clays. Fired clay has superior strength as compared to unfired clay. The tiles were stacked in multiple layers in order to maximize the space in the kiln. Multiple firings took place until all tiles were adequately fired.

Formwork

Arch Form Design

In order to be constructed, the arches needed to be propped and guided by temporary formwork. To create the arch, mortared flat tiles would be laid across the top of the formwork and allowed to set.

A hollow, braced catenary arch shape was designed for each side of the dome using AutoCAD. The individual components were modelled with square joints to connect together.



Students building the arch forms

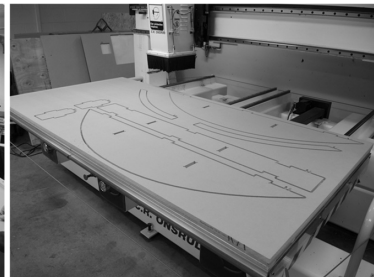

Routed arch formwork components (base x1, sides x2, internal braces x2, curved side braces x2)

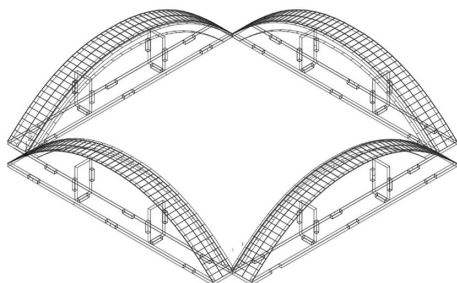

Isometric view of arch formwork design

Arch Form Construction

With the exception of the thin, curved top, the modeled individual components of the arch forms were routed out of 1" thick medium-density-fiberboard.

Students then constructed the forms. The base, internal braces, and sides were connected together at the joints using wood glue. The balsawood top was then screwed on to the top of the side pieces. Finally, the connection of the top to the side was braced on both sides by the curved side braces, again using screws.

Formwork

Grid shell Guides Design

While experienced masons are often able to create masonry vaults with little to no guidance, the class unfortunately lacked that level of skill. As such, a form was created to guide the vault's shape. The vault was created in AutoCAD by sweeping two catenary shapes over each other, allowing for a surface that can be created using multiple flat planes connected together.

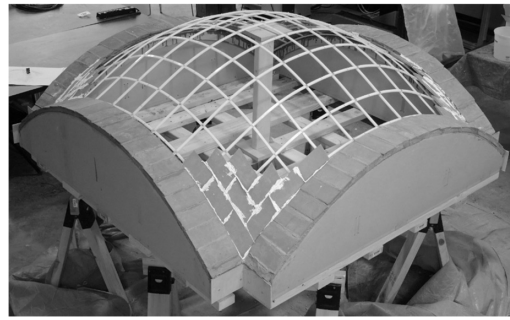

Compiled arch and grid shell formwork supporting the arches and layer 1

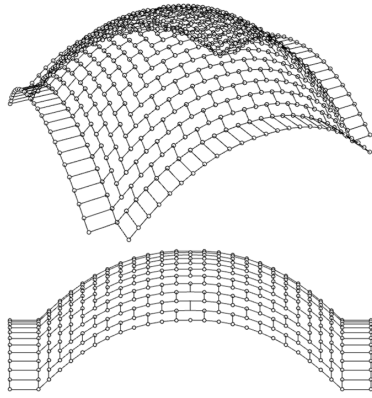

Isometric and side view of vault shape design (two swept catenary curves)



Underside of the grid shell guide at a corner

Grid shell Guides Construction

The guides were constructed with flat flexible plastic strands connected at the joints with lubricated rivets. The outer ends were then curved into the appropriate catenary shape and the center was pushed up to allow for the design vault shape. The ends were then nailed to the inner side bracing of the arch form, completing the formwork.

The Arches

The arches are designed to direct the horizontal thrust from the dome's weight to the columns at the corners. The design uses two layers of clay tiles placed with mortar.

There are three essential steps to construct each arches:

1. Placing wooden brackets
2. First layer placement
3. Second layer placement

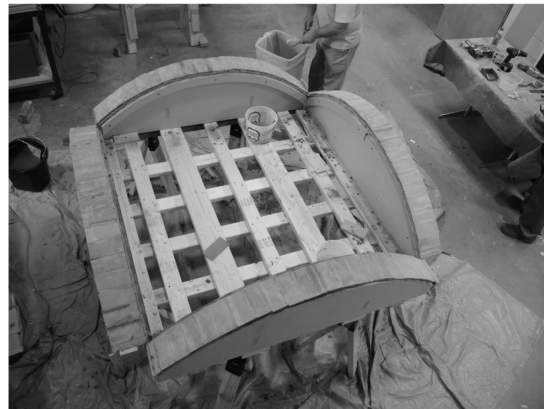

Top View of The Completed Four Arches

1: Placing Wooden Brackets

Wooden brackets are placed during construction as shown to prop the first tiles and prevent further slippage as the arches gradually form

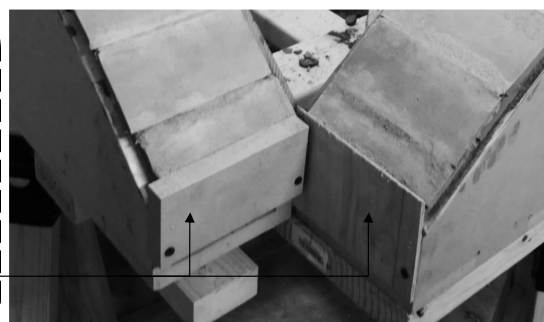
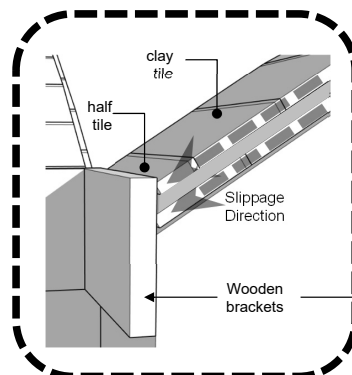

Wooden bracket placements

2: First Layer Placement



The mortar is applied on the long edges of the tiles that then placed along the guide on the MDF formwork. No mortar applied between the tiles and the MDF surface. Tile placement starts at both end of each curve and progresses towards the center. At the top of the arches, "key tiles" (instead of keystones) are cut to size to close the remaining gap.

Laying the tiles; red arrows show direction of placement progression



"Key tiles" position

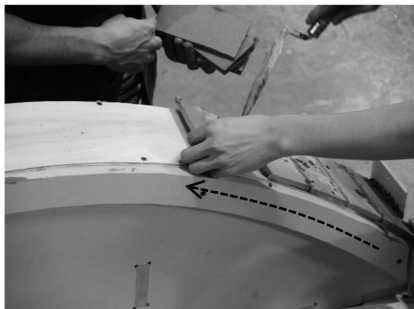

Placing a tile onto the formwork, red arrow shows direction of progress

Step 3: Second Layer

Following the same procedure but now with mortar application, we lay the second layer on the top of the first layer. Section Detail A shows the alternating projected placement of 1st and 2nd layers.

The two layers are applied in a running bond pattern, but with the tiles' headers towards the elevation of the arch.

Working on second layer

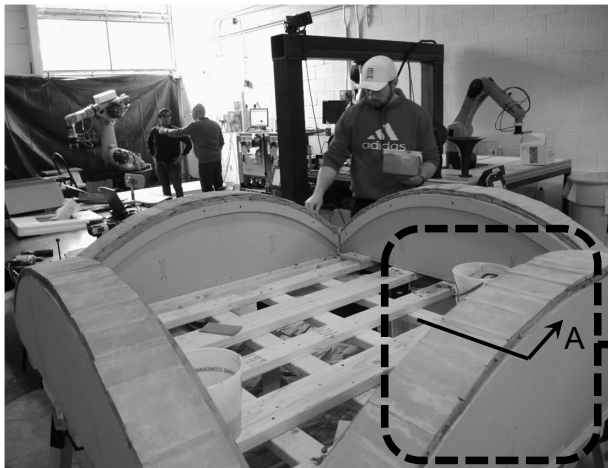

Running bond pattern of the two layers

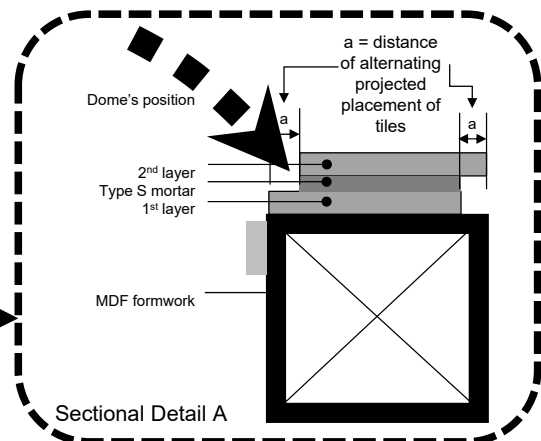
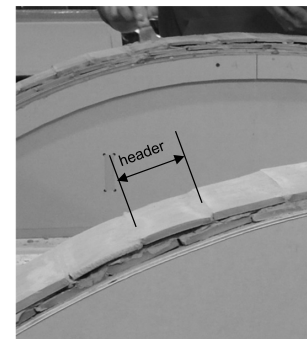

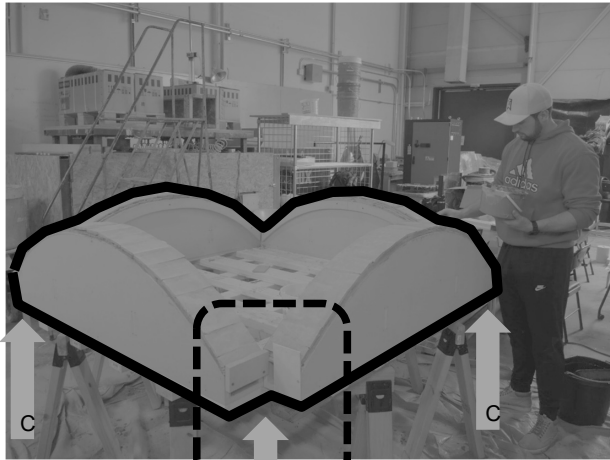

Conceptual scheme for future column placements

Corner Detail Concept

The four arches will channel the load to the columns (C) that will have capitals with specific receptacles designed to fit the arches' corner profiles. This explains the manner the corners of each arch are constructed.

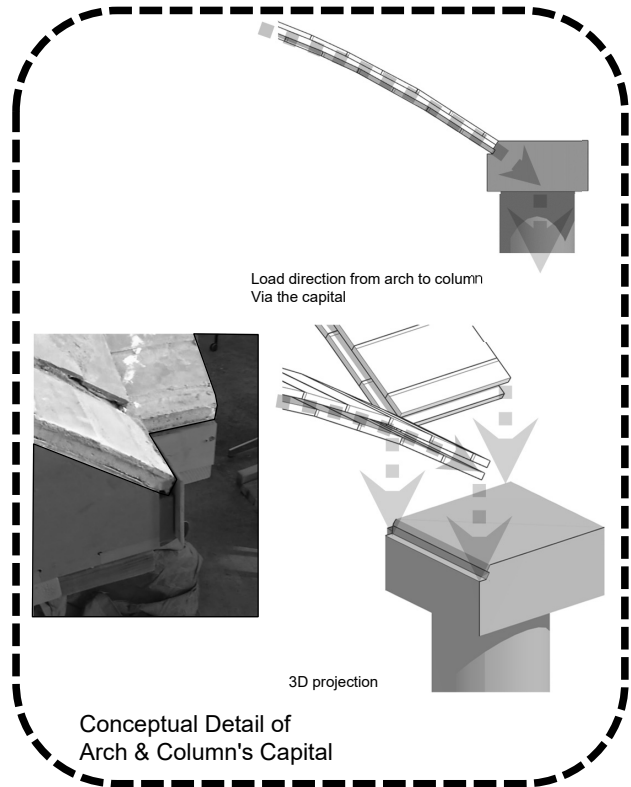

Load direction from arch to column
Via the capital

3D projection

Conceptual Detail of Arch & Column's Capital

Layer 1

Designing Layer 1

The first layer was designed in AutoCAD to fit the 6'x6' dimensions of the completed arch. The angles of individual tiles were optimized into 3 groups to create a round shape from flat, parallelogram elements. The red tiles in Fig. 1 have the sharpest corner angles at 67°, the green are 71°, and the unshaded tiles are rectangles.

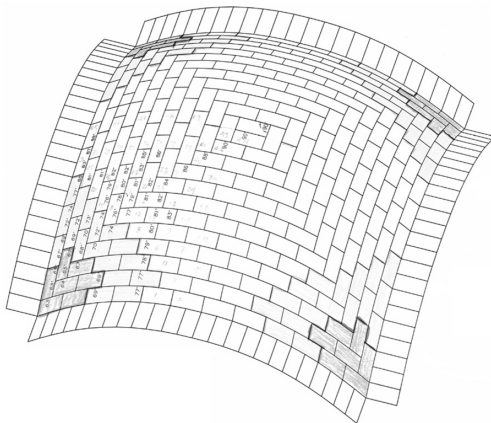

Figure 1: Tile pattern for placement of 3 types of tiles



Figure 2: Angled tiles A (67°), B (71°), and C (90°) were hand cut using wooden templates



Figure 3: The tiles were placed using mortar and plaster

Layer 1 Materials

The tiles are made of a red clay which was cut, then fired. The first layer of bricks around the four sides of the arch were laid with mortar, and the first layer of tiles in the center are connected with a plaster mixture. These adhesive materials were mixed ourselves to achieve the right workability and strength.

Layer 1

Starting to Place Layer 1

To begin creating layer 1, students starting placing tiles according to the Figure 1. Students can be seen placing the tiles using plaster in Figure 4 . Often, tiles were held together using paper clips as can be seen in Figure 5 to maintain the desired shape of the arch. The beginning of the arch can be seen in Figure 6.



Figure 4: Students Placing Tiles

Figure 7: Cutting Tiles

Cutting Tiles

Once the first layer of the arch began to reach the top the students begin to notice that the design for the shape of the tiles no longer worked and some of the tiles needed to be cut as can be seen in Figure 7.



Figure 8: Students Finishing Layer 1

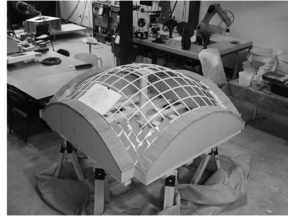

Figure 6: The Corners of Layer 1



Figure 5: Paper Clipped Tiles

Completing Layer 1

To finish layer one, the students had to carefully place the cut tiles at the top of the arch. They had to ensure that they were not leaning on the arch as this could have caused the arch to fall. Figure 8, shows the students completing the first layer of the arch.

Layer 1

Complete Layer 1

Completed layer one can be seen in Figure . Once the layer was completed, the students went back and added more plaster to any joint that had buckled or had gaps, (Figure 10). Once this was done, the layer was allowed to dry before the students begin layer 2.

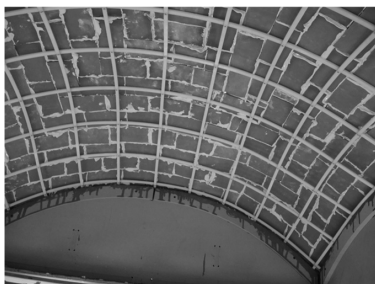

Figure 11: Underneath Layer 1



Figure 10: Adding Plaster



Figure 9: Layer 1 Complete

Underneath Layer 1

Layer one was also photographed from underneath, as can be seen in Figure 11. We can see that the students successfully created an arch along the formwork that meet in the middle to create the first layer of the arch.

Second Layer Tiles

Cement mortar binder

The second and final layer of tiles was added using type S mortar as a binder. Attention was given to ensure joints in the first layer were overlapped by second layer tiles to obtain maximum strength.



Overlapping pattern of tile layers lent to maximum strength of final design

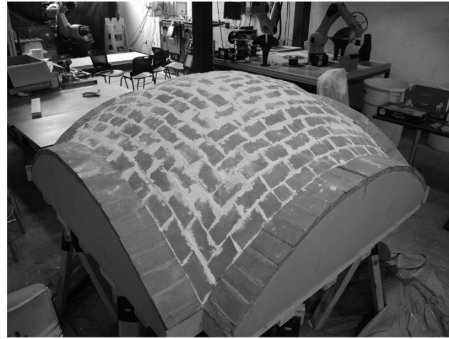

Project End Result

Laying of tiles

The first layer was wet with water to prevent the tiles from absorbing moisture from the mortar. This was done as low water/ cement ratios in mortar lead to reduction of binding capabilities. A mortar bed was then laid on the first layer and second layer tiles were gently pressed into the bed. Excess mortar was removed using a trowel. Care was taken to keep mortar at same consistency throughout time of appliance and wetting of first layer tiles was maintained.



Laying of the mortar bed